

**3D-Effekt**

**88084.534**

<b>1</b> 4 x 2802	<b>2</b> 4 x 2801	gedämpft <b>3</b> 3 x 1506	ungedämpft <b>4</b> 3 x 1507	<b>5</b> 6 x 1614
<b>6</b> 3,5 x 15 27 x 2804	<b>7</b> 8 x 30 16 x 2861	<b>8</b> 3 x 15 6 x 2803	<b>9</b> 3 x 1098	<b>10</b> 4 x 30 6 x 2812
<b>11</b> 5,8 x 55 3 x 2840	<b>12</b> 8 x 30 3 x 2842	<b>13</b> 3 x 2843	<b>14</b> 6 x 2865	<b>15</b> Leim 1 x 2863
<b>16</b> 24 x 2819	<b>18</b> 3,5 x 17 20 x 2832	<b>19</b> 6 x 2552	<b>20</b> 1 x 2 x 2 x	
<b>21</b> 2 x 4 x				

**27** 2 x    **28** 3 x    **29** 2 x

**30** 2 x

**31** 4 x

**32** 2 x

**33** 1 x    **34** 1 x

371 mm

379 mm

Das beigefügte Wandbefestigungsmaterial (Dübel und Schrauben) eignet sich nur für festes Mauerwerk (z.B.: Beton- oder Ziegelwände). Für andere Wandaufbauten sind eventuell Spezialdübel und andere Schrauben notwendig. Ziehen Sie gegebenenfalls eine Fachkraft zu Rate.

Приложенный материал для крепления к стене (дюбели и винты) пригоден только для жестких кладок (например, бетонные или кирпичные стены). Для других настенных конструкций необходимы смотря по обстоятельствам специальные дюбели и другие винты. При необходимости проконсультируйтесь у специалиста.

Załączony materiał do mocowania do ściany (kolki rozprężne i wkręty) nadaje się tylko do ścian murowanych (np. z betonu lub cegiel). Do ścian wykonanych w innych technologiach konieczne być mogą specjalne kolki rozprężne i inne wkręty. W razie potrzeby skorzystaj z fachowej pomocy.

The accompanying wall mounting hardware (anchors and screws) is suitable only for solid masonry (eg concrete or brick walls). For other wall structures are possibly special anchor bolts and other necessary. Tighten if necessary, an expert.

De begeleidende wandmontage hardware (pluggen en schroeven) is alleen geschikt voor massief metselwerk (bijvoorbeeld beton of bakstenen muren). Voor andere muur structuren zijn eventueel bijzondere ankerbouten en andere noodzakelijke. Draai indien nodig, een deskundige.

Le mur d'accompagnement matériel de montage (chevilles et les vis) ne convient que pour la maçonnerie solide (par exemple en béton ou des murs de briques). Pour les structures de mur d'autres sont peut-être spéciale boulons d'ancrage et d'autres nécessaires. Serrer le cas échéant, un expert.

Il muro di accompagnamento hardware di montaggio (tasselli e viti) è'e adatto solo per muratura piena (ad esempio calcstruzzo o muratura). Per le altre strutture murarie sono forse speciali bulloni di ancoraggio e necessari di altri. Serrare se necessario, un esperto.

Ekteki duvara sabit montaj malzemeleri (dübel ve vidalar), sadece sağlam duvarlar için (örnek: beton veya tuğla) elverişlidir. Başka duvarlar için özel dübeller ve farklı vidalar gerekebilir. Gerekliğinde bir uzmana danışınız.

**1**

16 mm

16 mm

**2**

oben

oben

**3**

- 2 4 x 2801
- 7 8 x 30 8 x 2861
- 15 1 x 2863

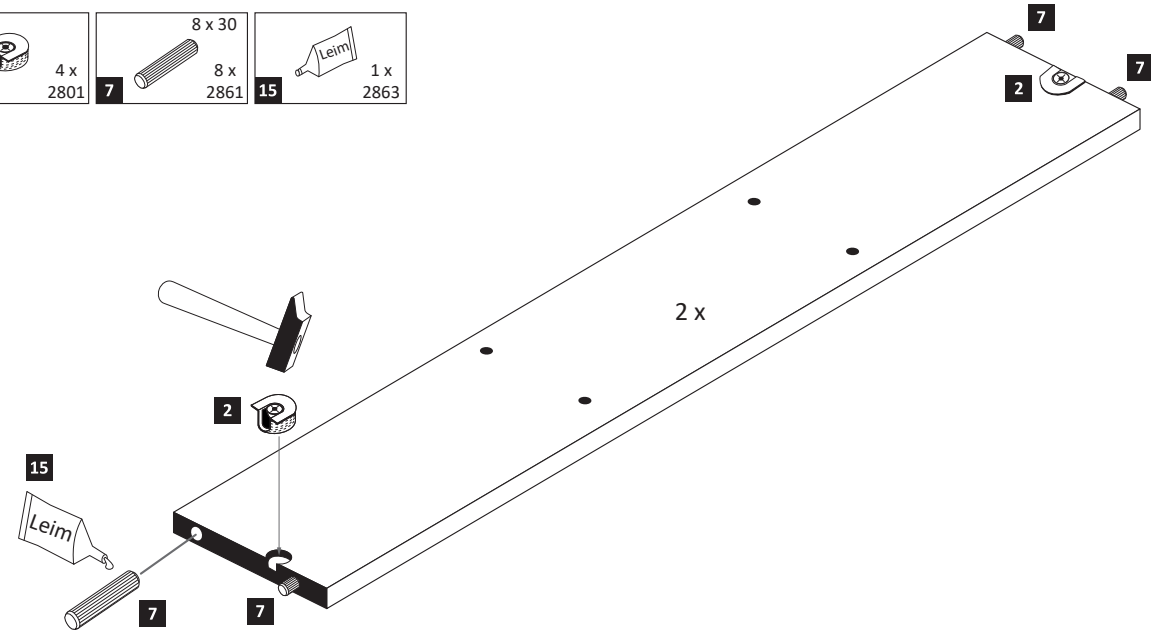
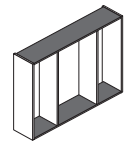

**4**

- 6 3,5 x 15
- 3 x 2804

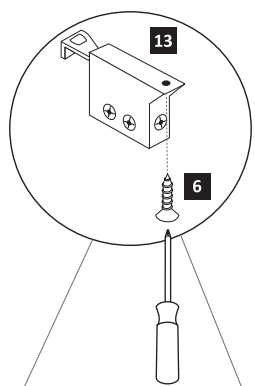
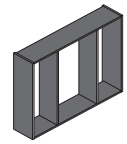

- 15 1 x 2863
- 20 min.
- D Leim
  - GB Glue
  - NL Lijm
  - PL Klej
  - TR Tutkal
  - F Colle
  - I Colla

Ansicht von links

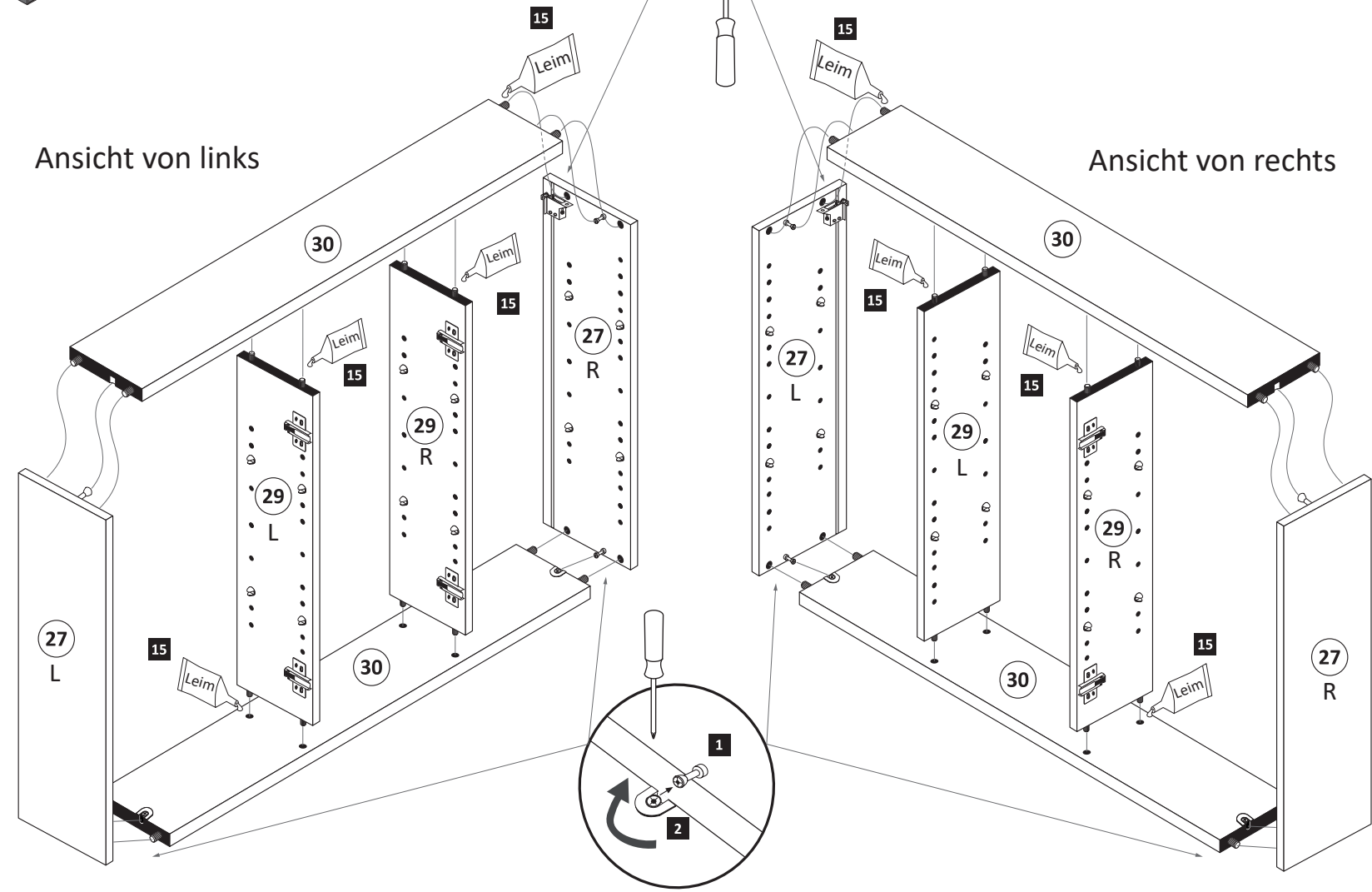

Ansicht von rechts

**5**

Bitte nur eine Variante auswählen und den entsprechenden Ausschnitt in einer Größe von maximal Trafobreite wie Trafohöhe - 10 mm aussägen. Trafomontage wird im Schritt 7 durchgeführt.

Variante 1: Trafomontage unten

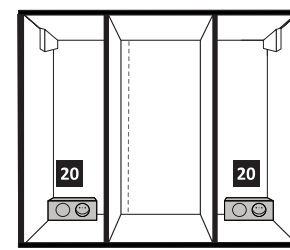

Trafo unten links

Trafo unten rechts

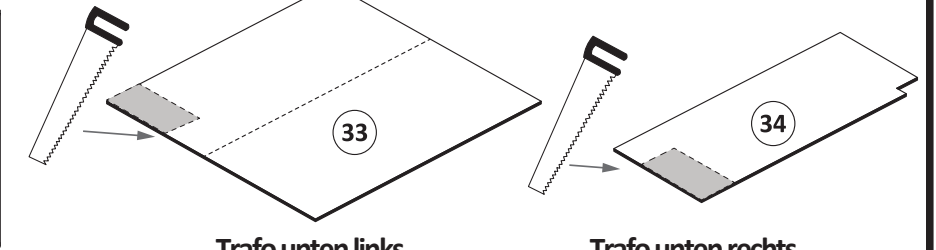

Variante 2: Trafomontage oben

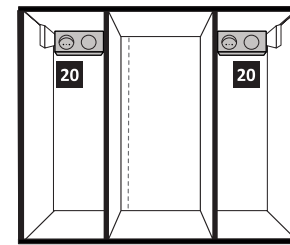

Trafo oben links

Trafo oben rechts

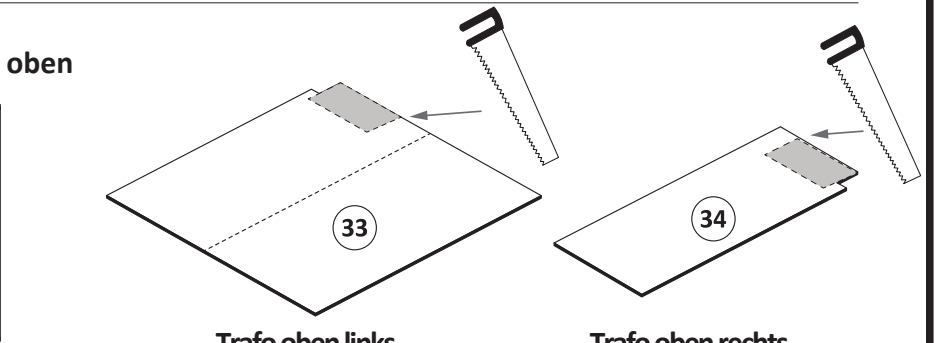

**6**

- 20 3,5 x 17 20 x 2832
- 21 6 x 2552

**ACHTUNG!**  
Folgende Montageschritte mit dem Beispiel „Trafomontage Variante unten links“!

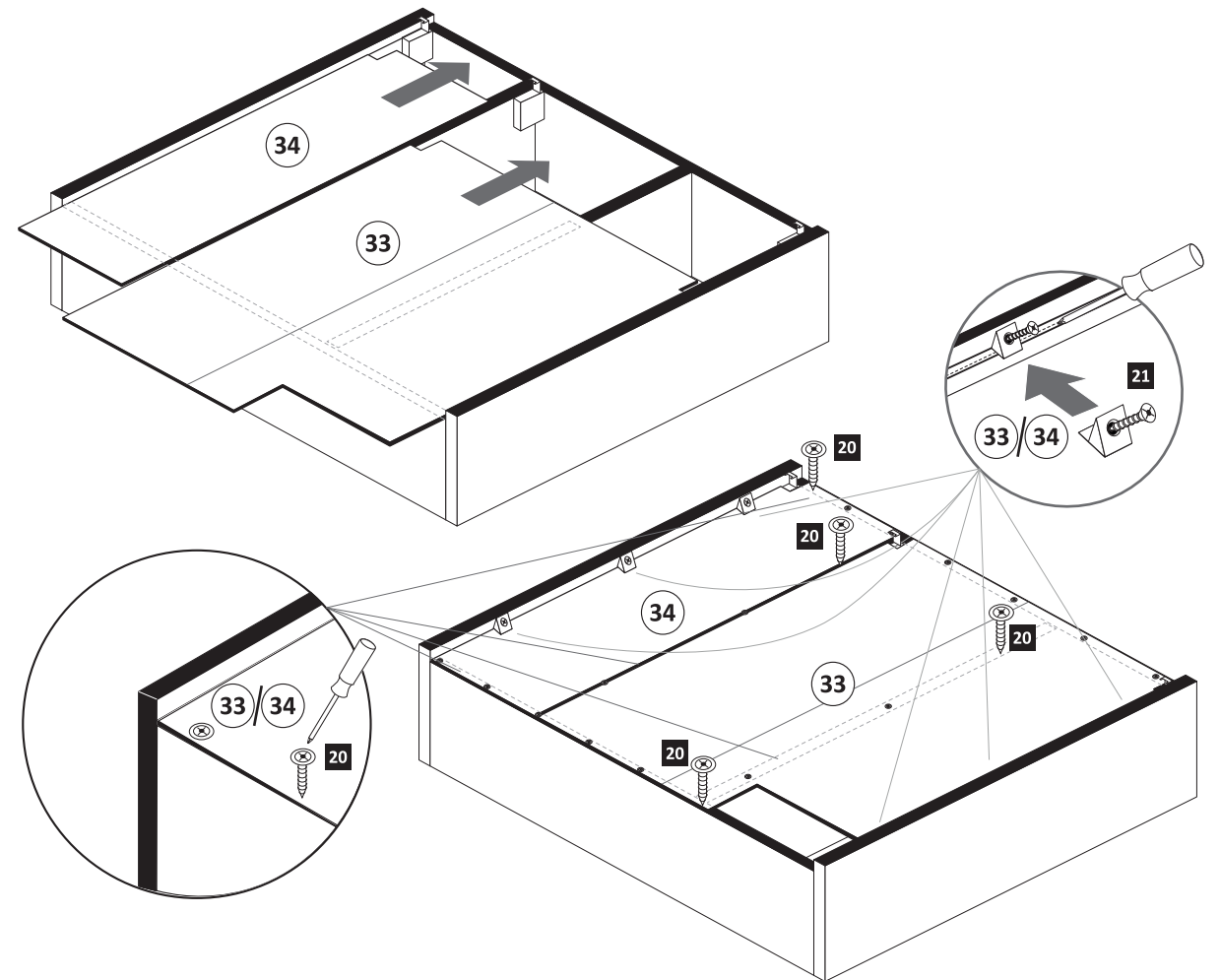

**7**

20 1x 2x 2x

**8**

**10**

Scharniermontage

1. 2.

Scharnier lösen 2. 1. (drücken)

**9**

gedämpft 3x 1506 3  
ungedämpft 3x 1507 4  
3,5 x 15 12 x 2804 6  
6 x 2865 14

**11**

3 x 15 6 x 2803 8  
3 x 1098 9

Unten

12

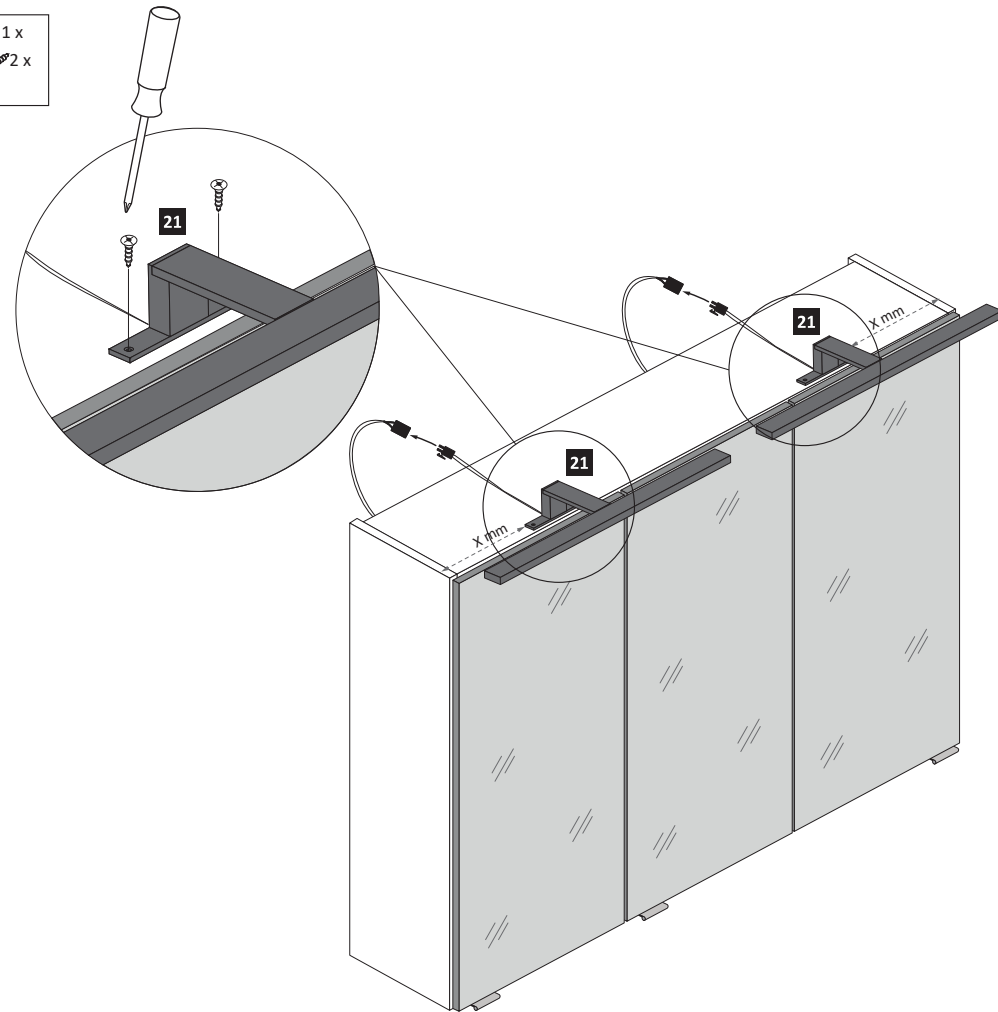
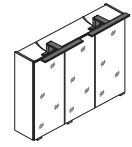
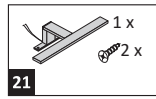

13

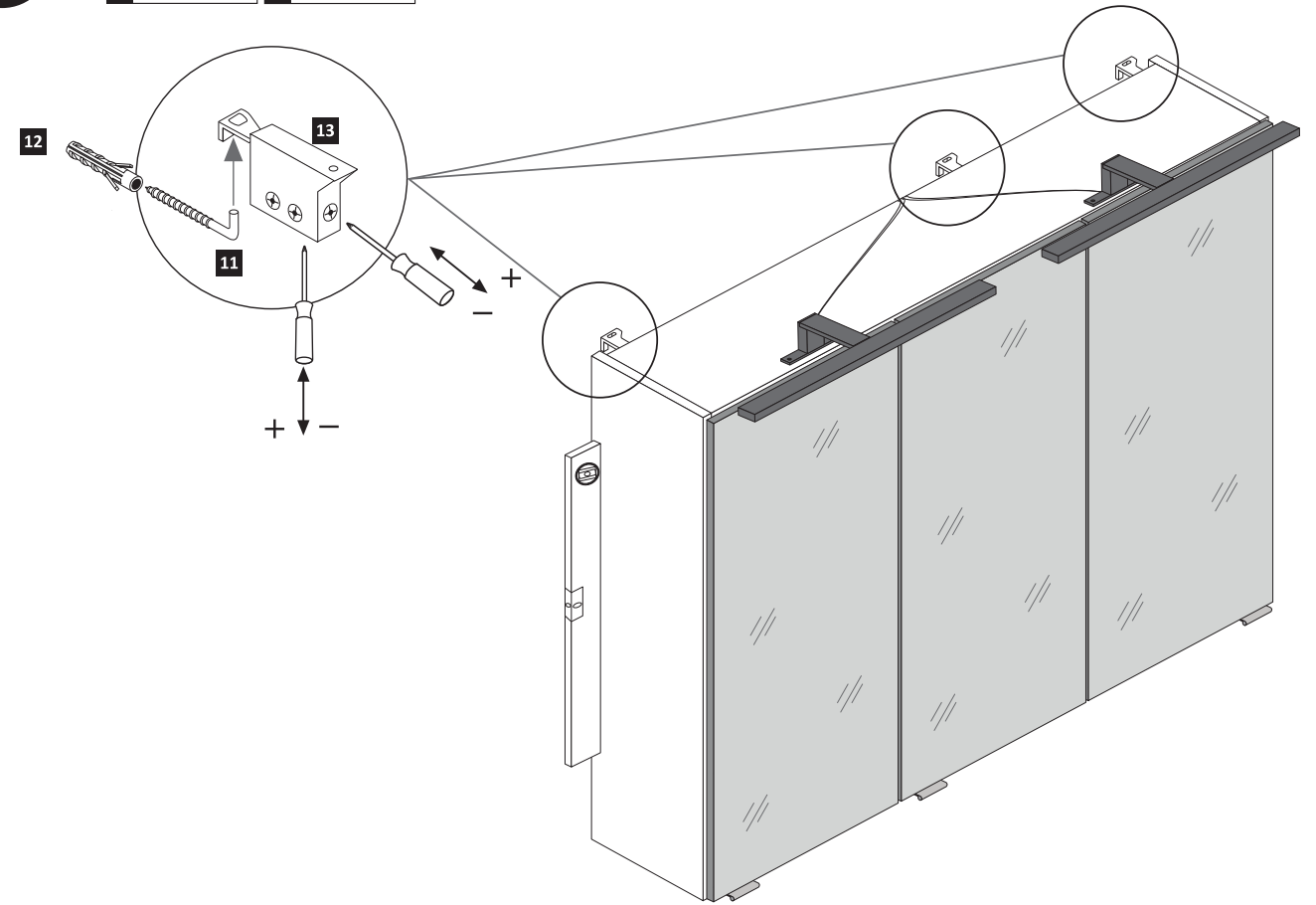
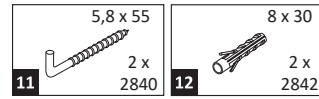

14

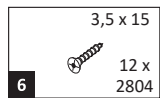

## 1. Türen einstellen.

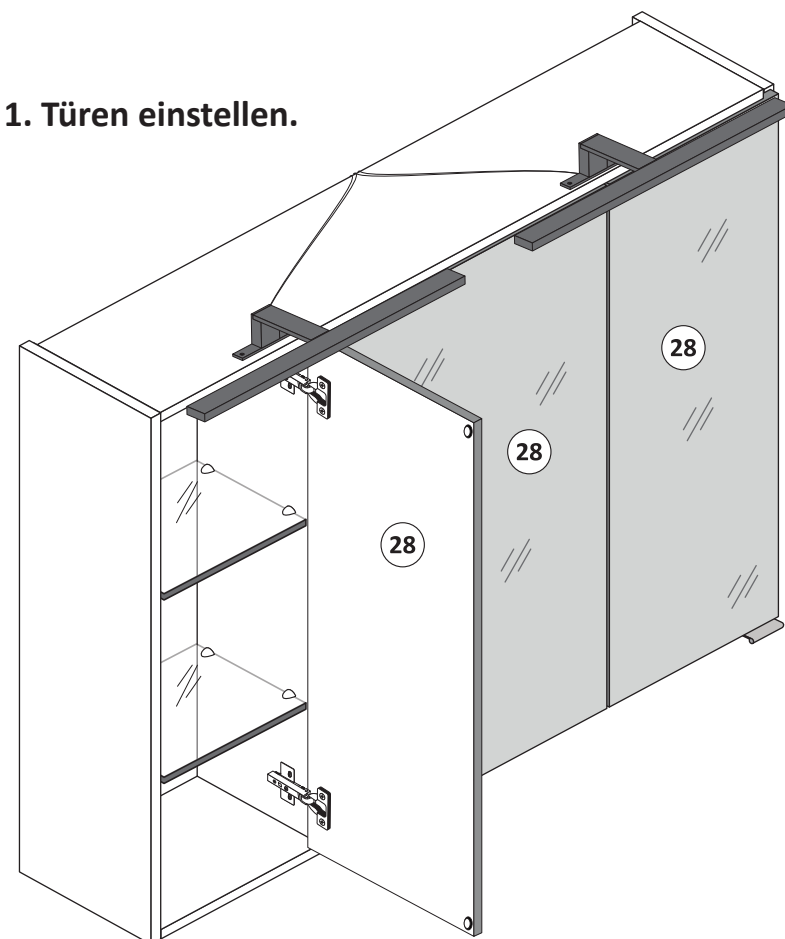
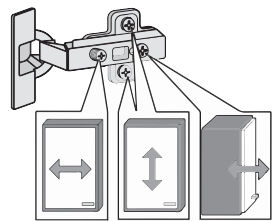

Achtung !!  
Aus Sicherheitsgründen ist die Montage der  
Sicherungsschrauben zwingend notwendig.  
Nachdem montieren der Sicherungsschrauben  
ist die Höheneinstellung der Türen nicht mehr  
möglich!



## 2. Sicherungsschrauben montieren.

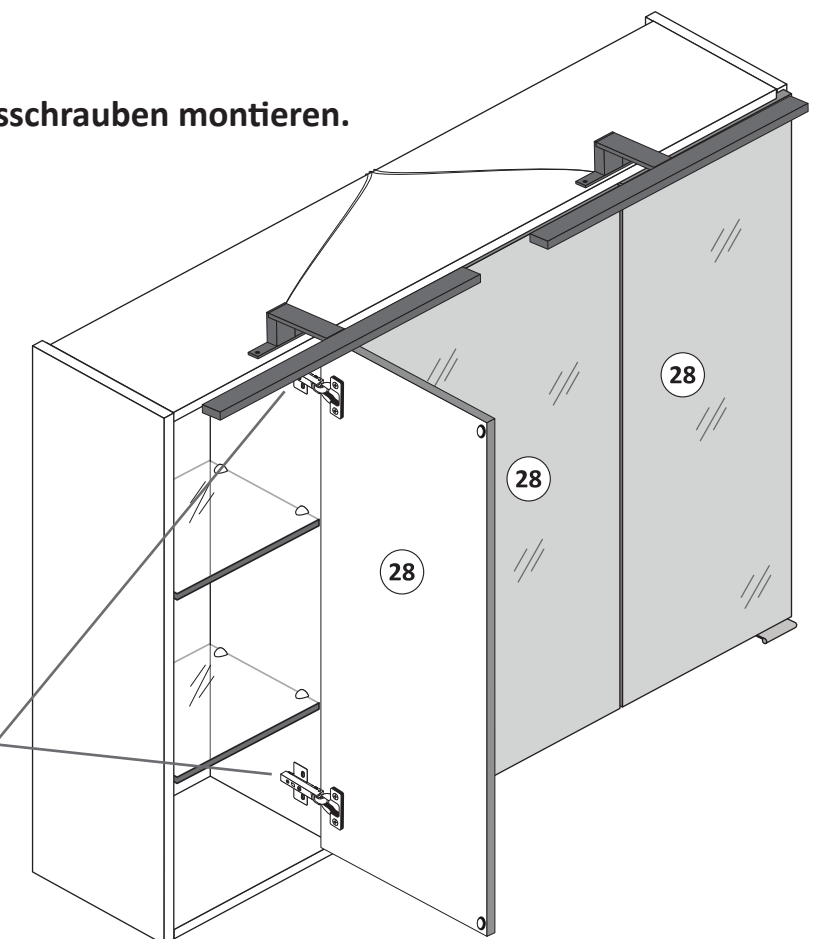
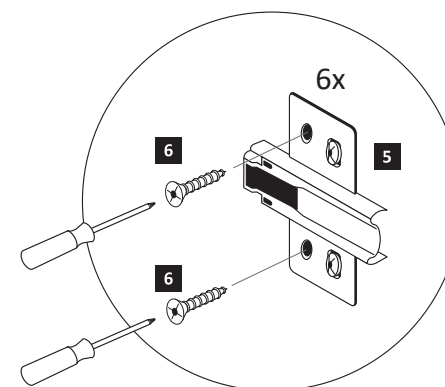



**D**

**Wichtige Sicherheitshinweise**

Die Installation Ihrer neuen Leuchte darf ausschließlich von autorisierten Fachpersonen durchgeführt werden.



[www.till-hilft.de](http://www.till-hilft.de)

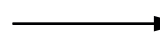

Montagehilfen



**PL**

**Ważne wskazówki dotyczące bezpieczeństwa**

Ta instalację nowej lampy mogą przeprowadzać wyłącznie autoryzowani instalatorzy



[www.till-hilft.de](http://www.till-hilft.de)

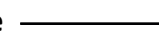

Montagehilfen



**GB**

**Important safety instructions**

The installation of your new luminaire may only be carried out by authorized specialists.



[www.till-hilft.de](http://www.till-hilft.de)

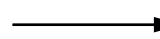

Montagehilfen



**SK**

**Dôležité bezpečnostné upozornenia**

Inštaláciu lampy smú vykonať výhradne autorizovaní



[www.till-hilft.de](http://www.till-hilft.de)

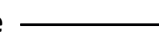

Montagehilfen



**FR**

**signes de sécurité importantes**

La L'installation votre nouveau luminaire doit uniquement être réalisée par des spécialistes autorisés



[www.till-hilft.de](http://www.till-hilft.de)

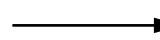

Montagehilfen



**HU**

**Fontos biztonsági utmutatások**

Az On Új lámpájának beszerelését kizárólag hivatalos szakember végezheti el



[www.till-hilft.de](http://www.till-hilft.de)

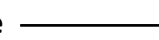

Montagehilfen



**IT**

**Important disposizioni di sicurezza**

L'installazione della il loro nuovo lampada può essere eseguita solo ed esclusivamente da personale tecnico autorizzato.



[www.till-hilft.de](http://www.till-hilft.de)

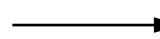

Montagehilfen



**RO**

**Instrucțiuni de siguranță importante**

Instalarea noii dumneavoastră lămpi este permisă exclusiv specialișilor autorizați



[www.till-hilft.de](http://www.till-hilft.de)

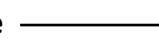

Montagehilfen



**NL**

**Belangrijke veiligheidsaanwijzingen**

De installatie van de nieuwe lamp moet worden uitgevoerd door vakbekwame personen worden uitgevoerd.



[www.till-hilft.de](http://www.till-hilft.de)



Montagehilfen



**TR**

**Önemli güvenlik uyarıları**

Yeni lamba montajı yetkin kişiler tarafından yapılmalıdır



[www.till-hilft.de](http://www.till-hilft.de)

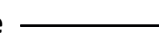

Montagehilfen



**CZ**

**Důležité bezpečnostní pokyny**

Instalaci nových svídel smí provádět pouze kvalifikovaný elektrikář



[www.till-hilft.de](http://www.till-hilft.de)

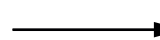

Montagehilfen



**RU**

**важная информация по технике безопасности**

Установка вашей новой лампы должна выполняться квалифицированным персоналом



[www.till-hilft.de](http://www.till-hilft.de)

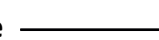

Montagehilfen



89904.330