

REPC-Nr.:

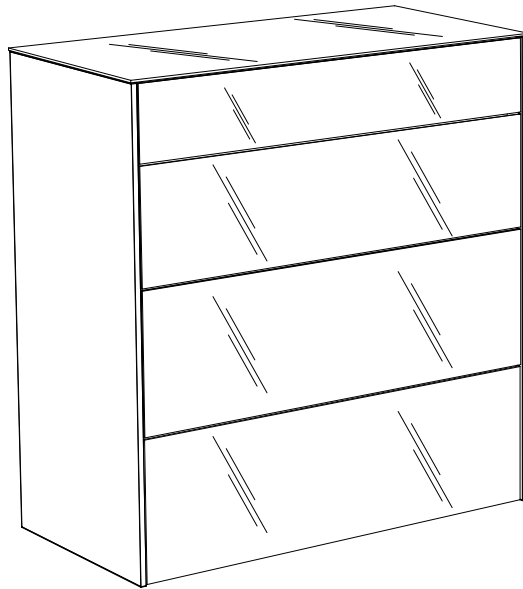

Artikel.-Nr.:

8002-KO-03-82

Montageanleitung.-Nr.:

MA1-00692

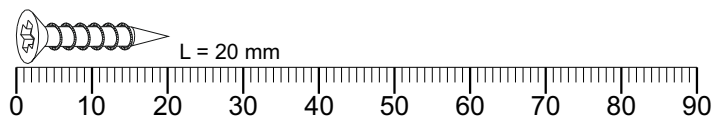
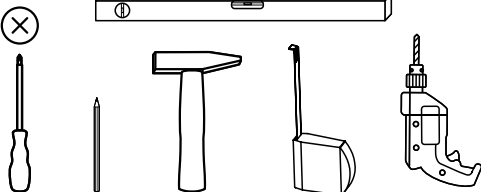
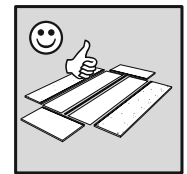
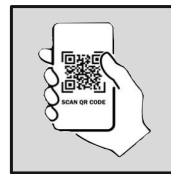
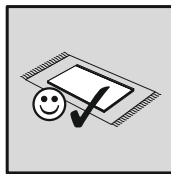
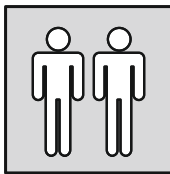
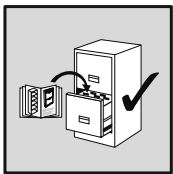

SCAN ME

Das Ersatzteil-Anforderungsformular finden Sie auf
The replacement parts requisition form you find on
<https://www.mausbacher.de/ersatzteile/>

Colli 1/2

BT1-00796

B03-134 9x		B05-185 4x		B05-302 3x	
B05-300 6x		B05-301 3x			

BT1-00797

B01-10 4x	 6,3x50	B01-122 6x	 4,0x13	B01-190 12x	 M4x20
B01-200 12x	 6,3x13	B01-30 18x	 3x16	B01-347 12x	 5x8
B01-36 3x	 4,0x40	B01-90 4x	 3,5x20	B02-10 20x	 ø15x12mm
B02-20 20x		B08-80 1x		B02-103 24x	 8x30
B05-20 16x					

BT1-00005

B02-173 4x		B01-123 8x	 4,0x15
---------------	--	---------------	------------

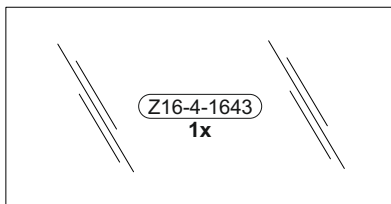
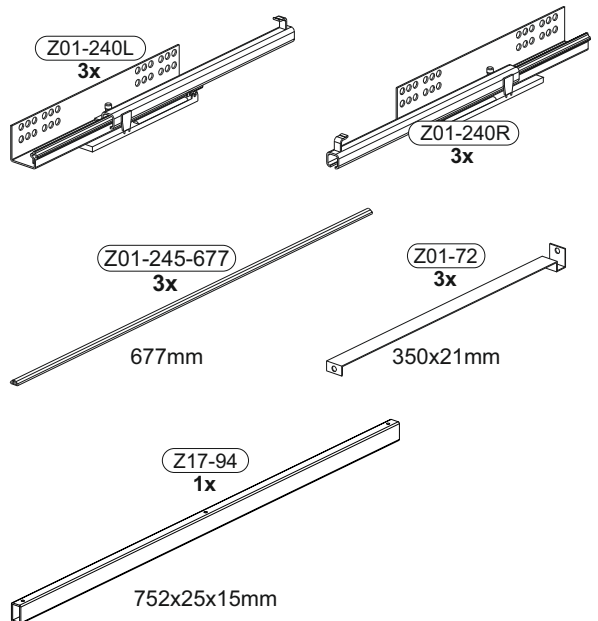

822 x 419

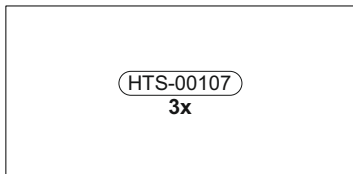

738 x 358

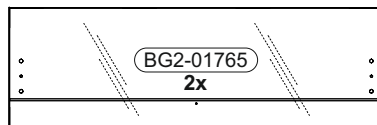

792 x 253

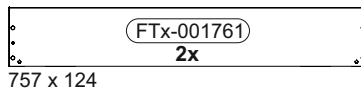

757 x 124

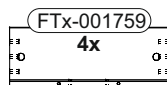

335 x 124

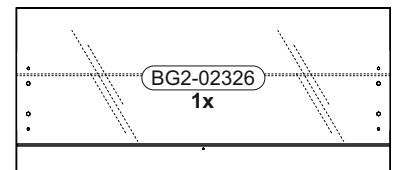

792 x 348

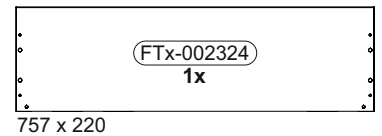

757 x 220

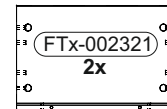

335 x 220

Colli 2/2

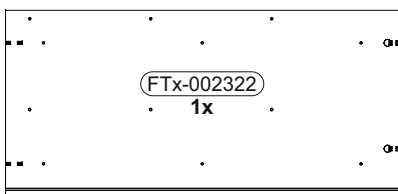

832 x 394

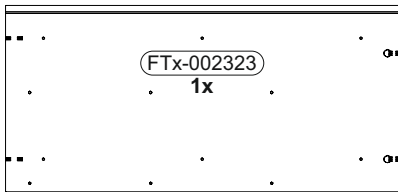

832 x 394

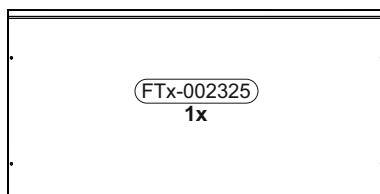

798 x 394

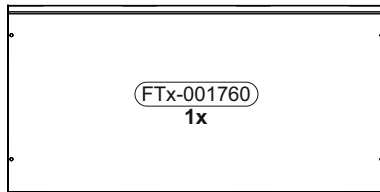

798 x 394

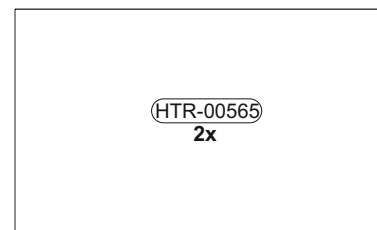

780 x 422

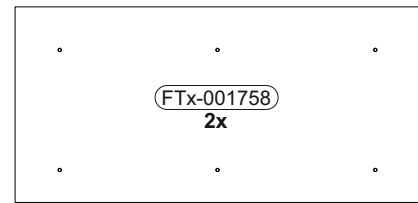

862 x 417



500 x 50

1

	4x	3x	

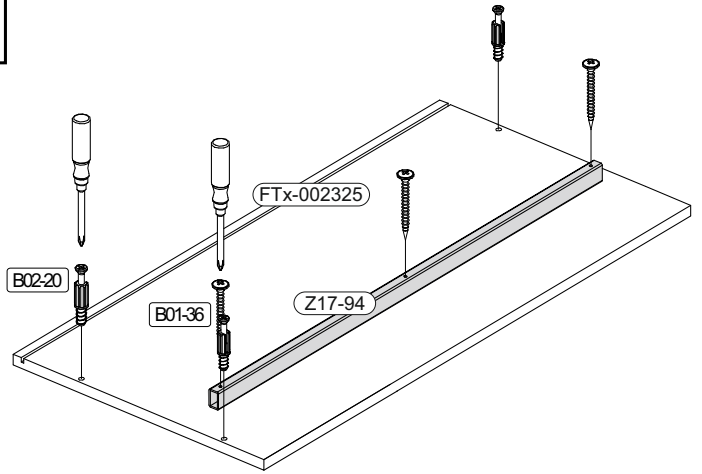
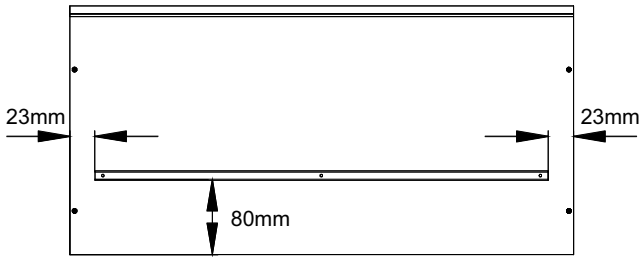

2

	2x		6x	

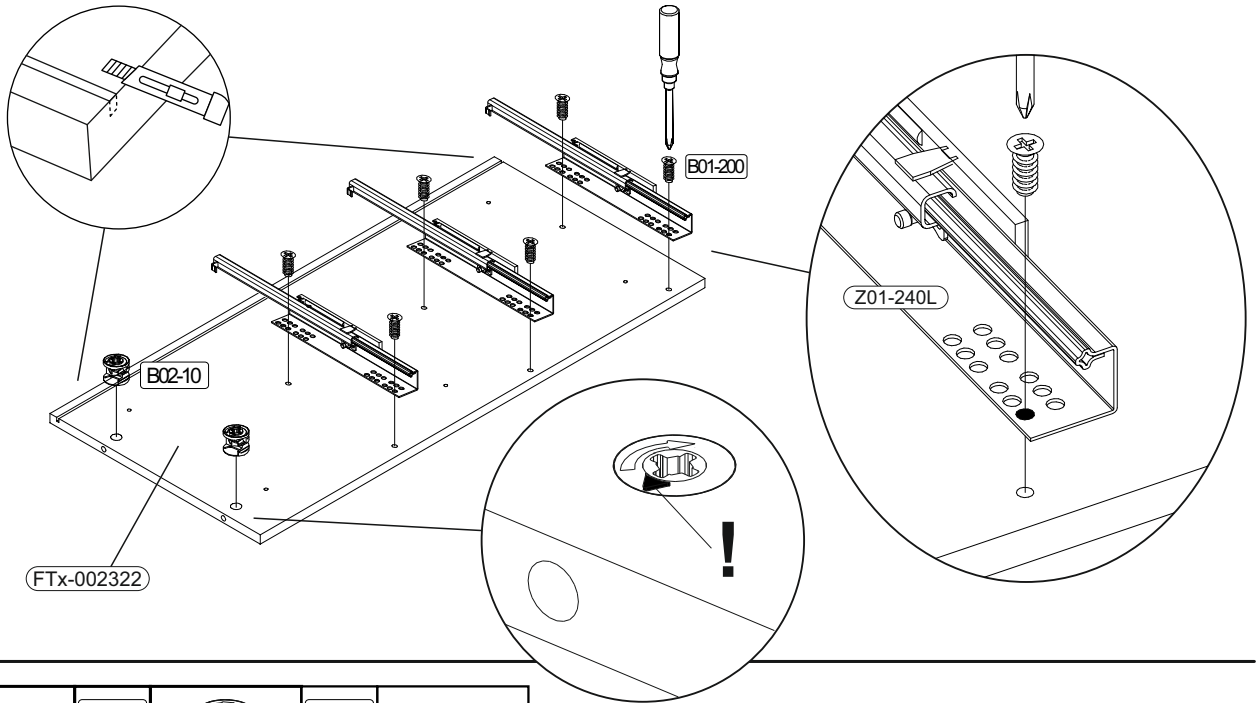

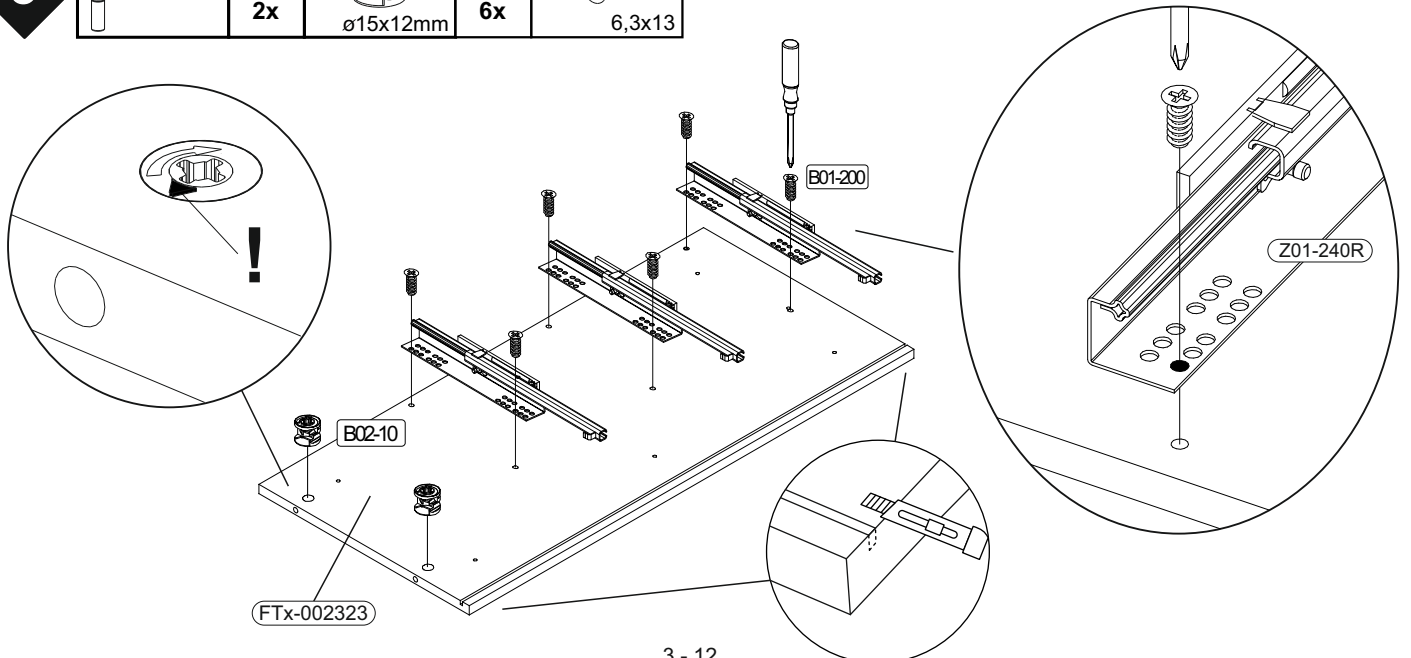

3

	2x		6x	

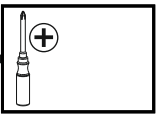

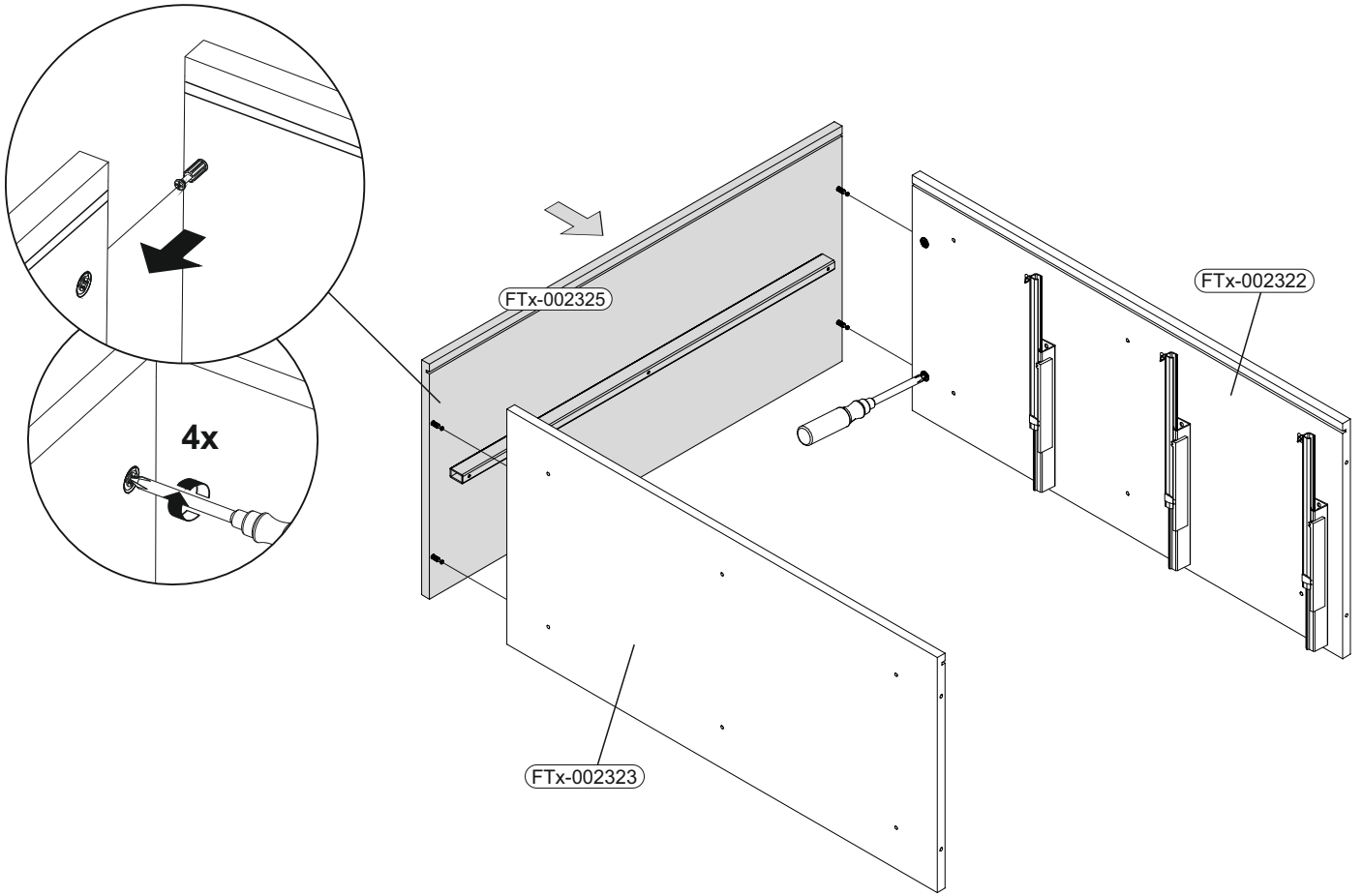



4 

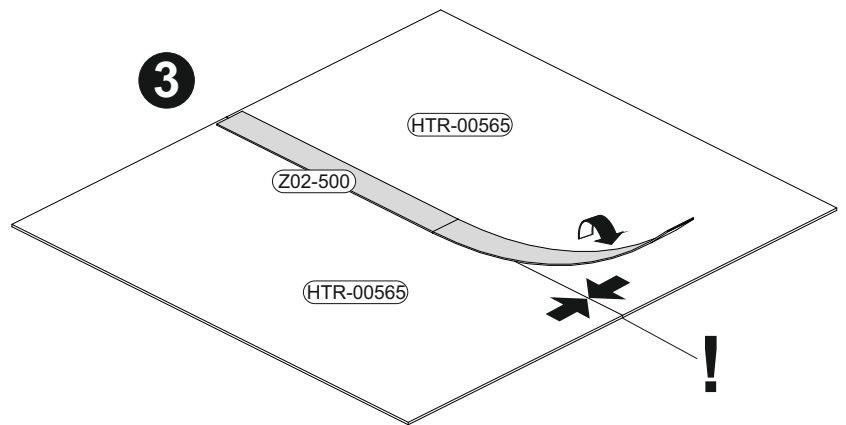
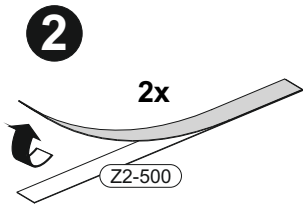

5 

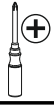

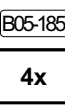

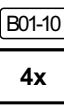
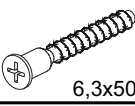

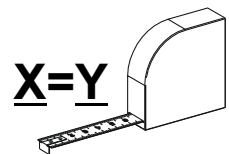
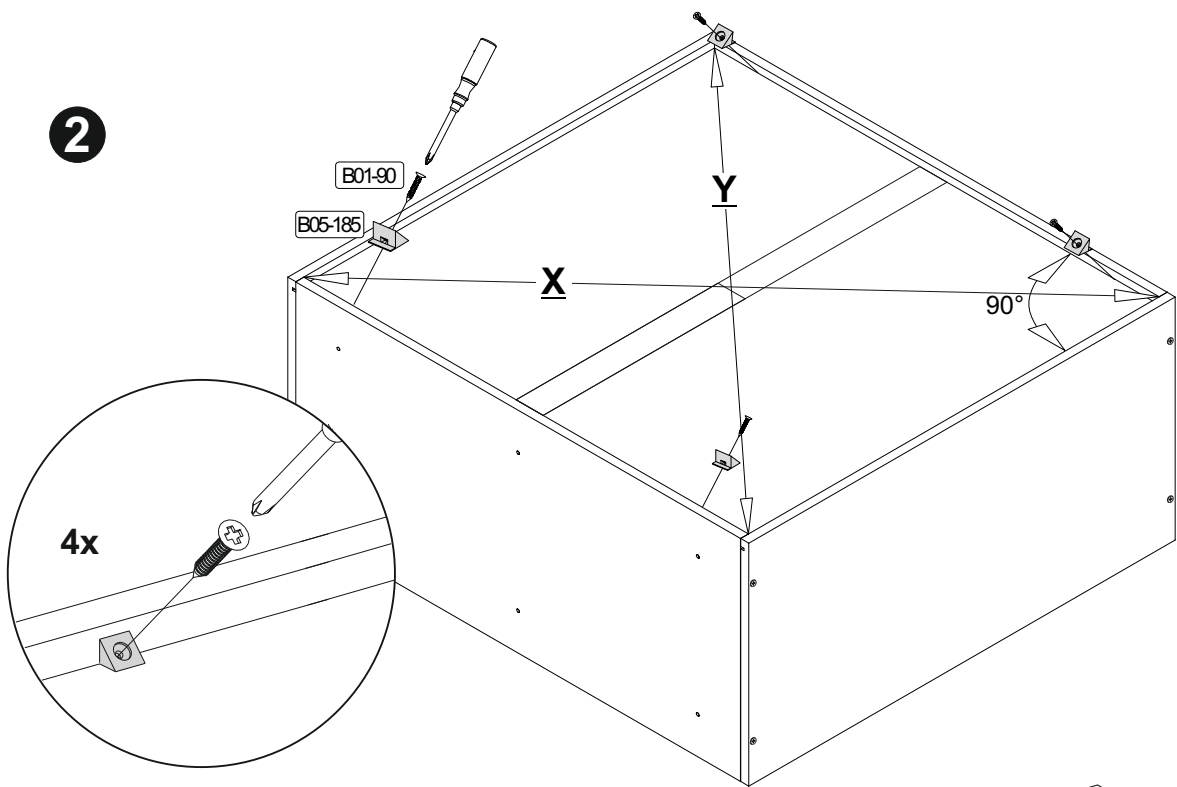
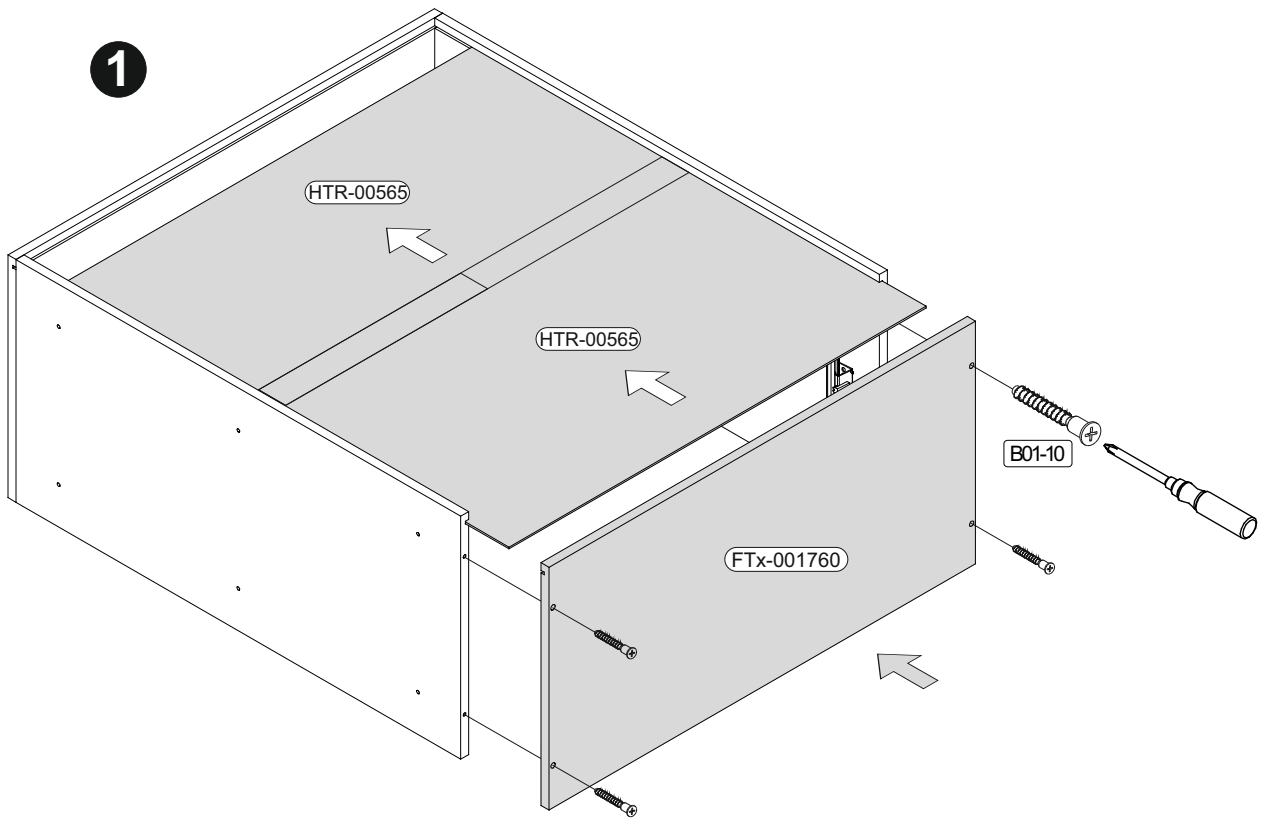
6

						
	B05-185		B01-90	3,5x20	B01-10	6,3x50
	4x		4x		4x	

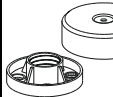

7

		B02-173		B01-123	
		4x		8x	4,0x15

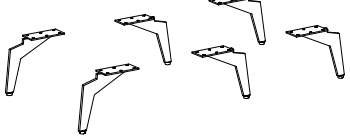
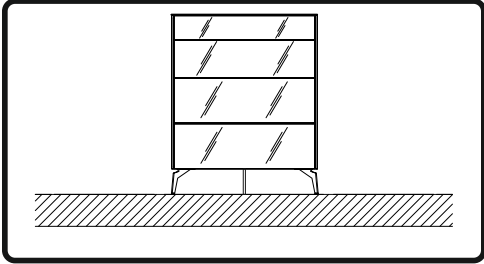

Artikel.-Nr.:
8001-FS-4er

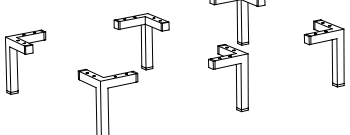
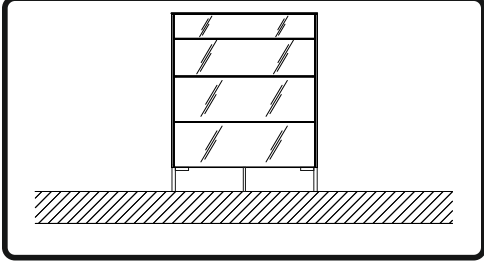

Artikel.-Nr.:
8001-FS-Eck-4er

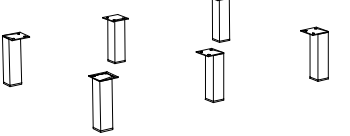
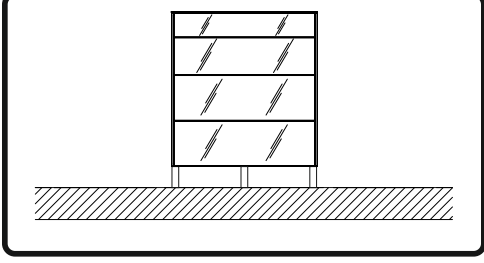

Artikel.-Nr.:
8001-FS-Gerade-4er

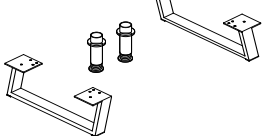
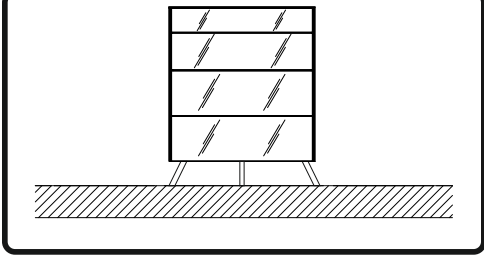

Artikel.-Nr.:
0775_Füße_2er

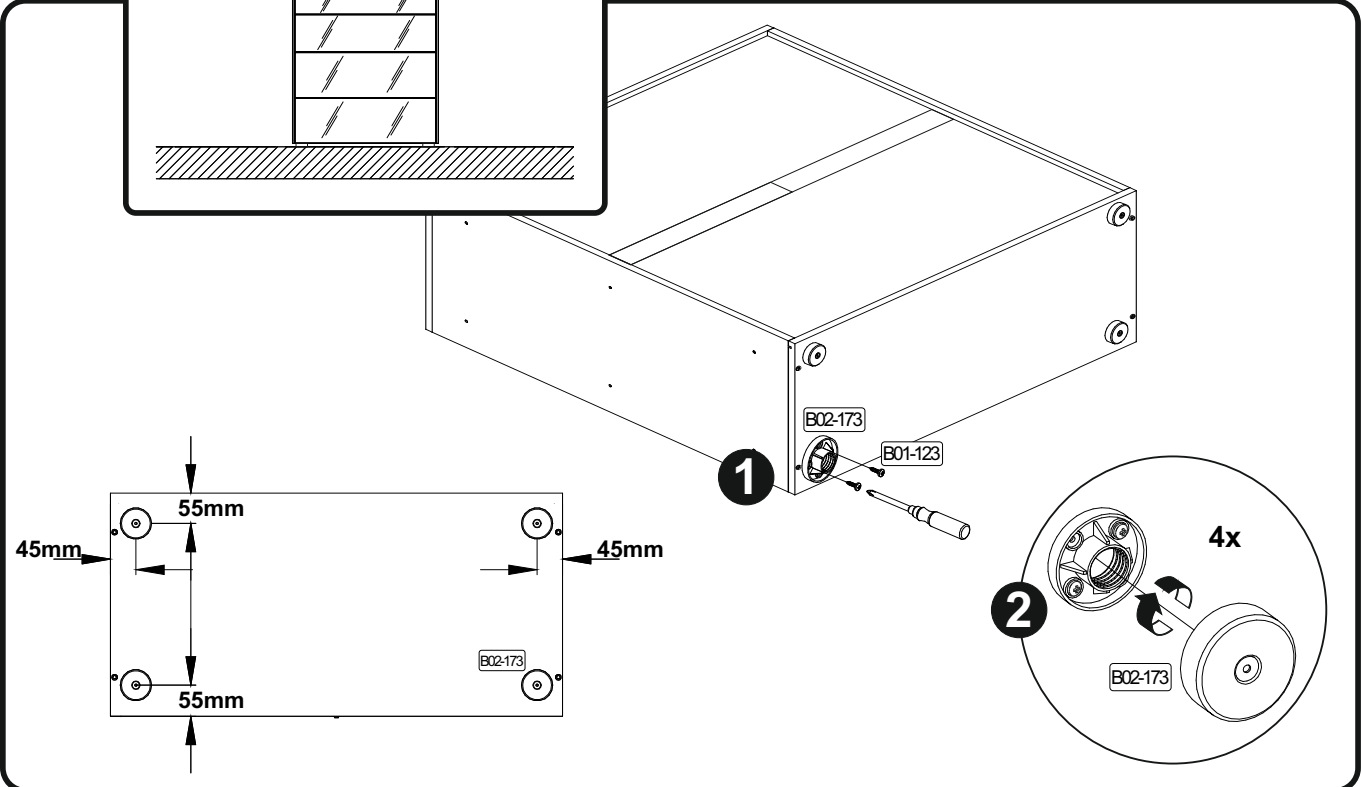
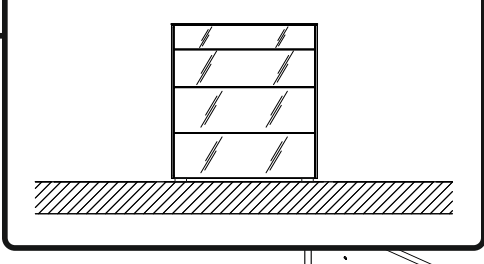

1

2

4x

B02-173

B01-123

B02-173

8

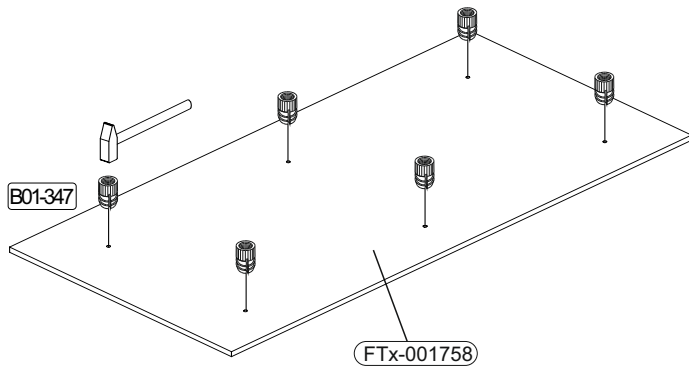
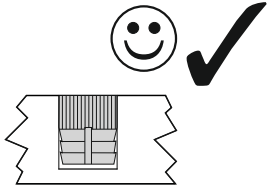
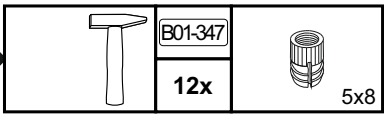

2x

9

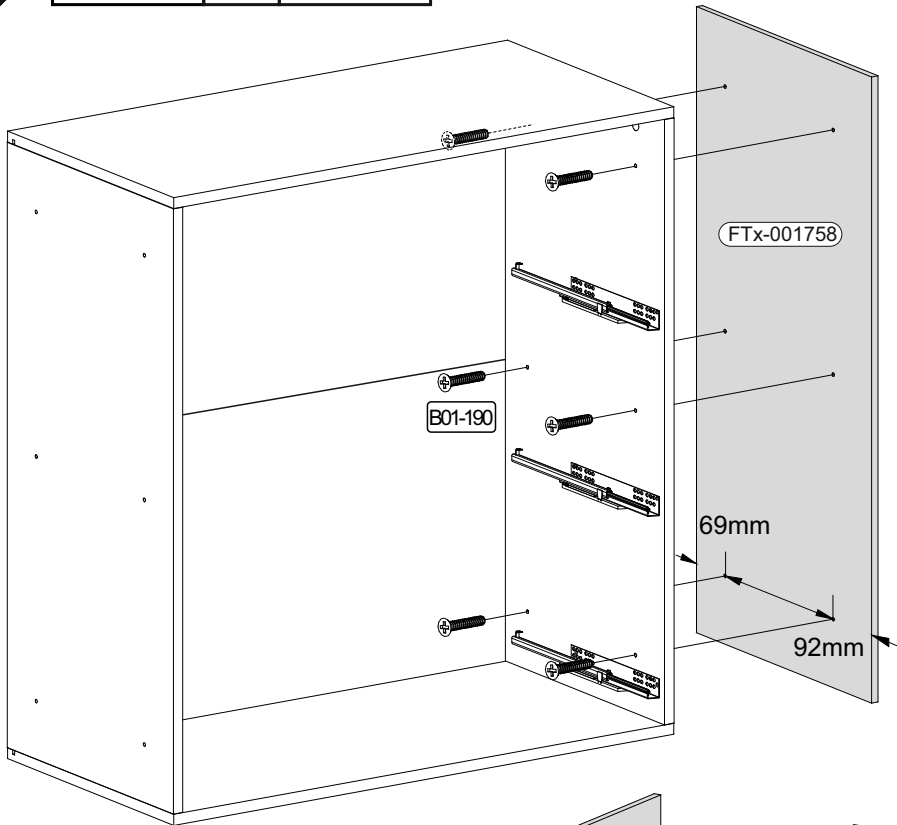
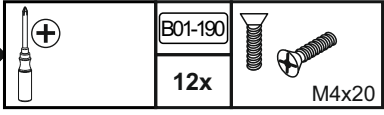

1

2

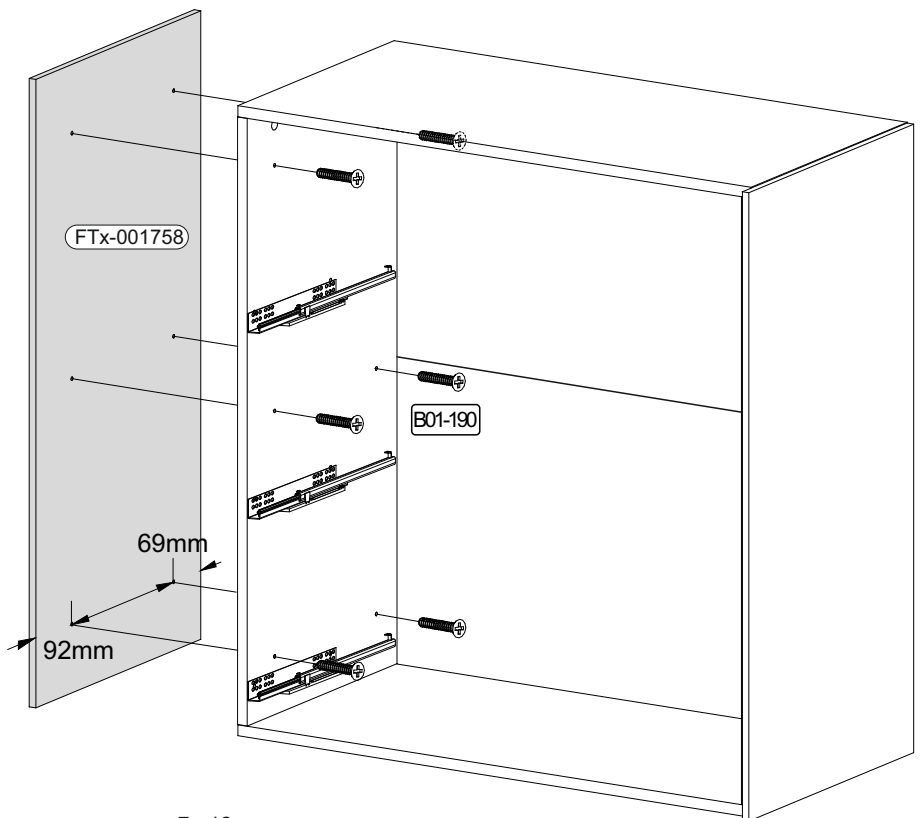

10

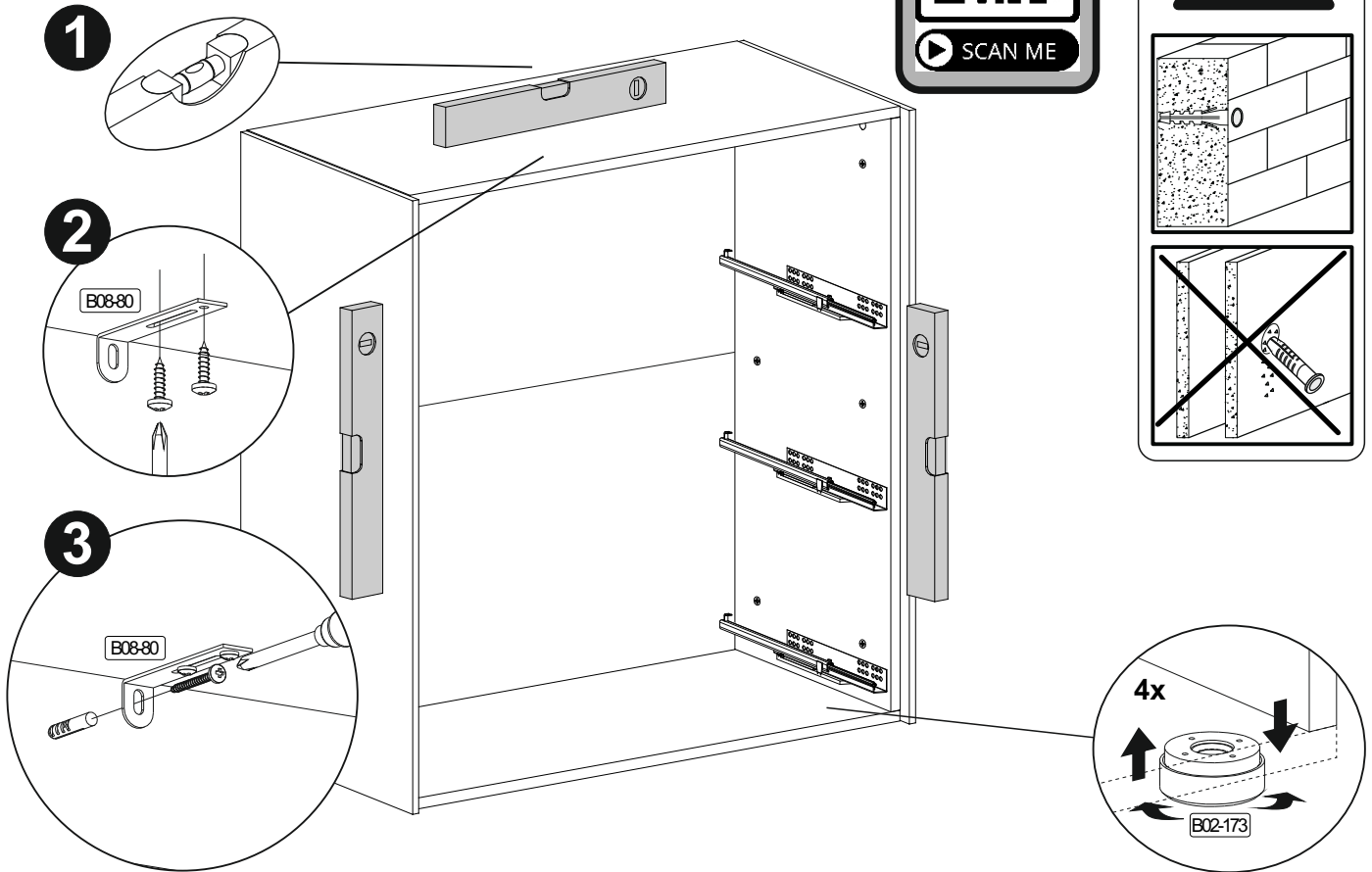
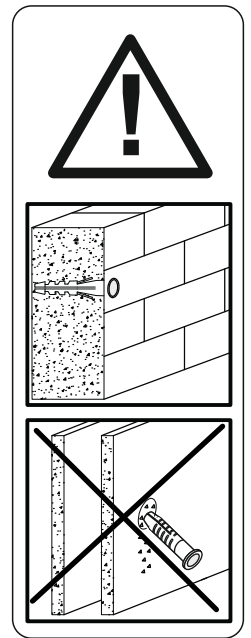
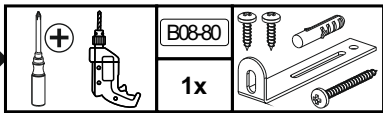

Achtung • Attention • Attenzione • Opgelet • Uwaga • Pozor • Figyelem • Atenție • Dikkat • Внимание • Fara • Vaara • Fare • Peligro	
(D)	Wandbefestigung dient als Kippschutz - unbedingt anbringen! Bei einigen Wandtypen kann ein Spezialdübel erforderlich sein!
(GB)	The wall fastening serves to prevent tipping - be absolutely sure to mount it! For certain wall types, a special wall plug may be necessary!
(FR)	La fixation murale sert de protection contre le basculement – à installer impérativement ! Pour certains types de murs il faut des chevilles spéciales !
(TR)	Duvardaki sabitleme, devrilmeye karşı bir emniyet tedbiridir ve mutlaka monte edilmelidir! Bazı duvar tiplerinde bunun için özel bir dübel gereklidir!
(IT)	Il fissaggio alla parete serve da protezione anti-ribaltamento – attaccarla assolutamente! Per alcune strutture di parete può essere necessario un tassello speciale!
(NL)	Bevestiging aan de muur dient als kantelbescherming – zeker en vast bevestigen! Bij enkele muurtypes is een speciale plug misschien vereist!
(RU)	Обязательно установите крепление на стене во избежание опрокидывания! Для некоторых типов стен может потребоваться специальный дюбель!
(CZ)	Montáž na stěnu slouží jako ochrana proti převrnutí – bezpodmínečně umístěte! U některých typů stěn může být zapotřebí speciální hmoždinka!
(HU)	A termék a falhoz kel rögzítési, különben az felborulhat! Egyes fal típusoknál speciális tiplőt kell használni!
(RO)	Sistemul de fixare la perete serve ca protecție la răsturnare - de montat obligatoriu! Pentru unele tipuri de pereți este posibil să fie necesar un diblu special!
(PL)	Mocowanie do ściany jest jednocześnie zabezpieczeniem przed przewróceniem – koniecznie zamontować! Do niektórych rodzajów ścian koniecznie zastosować specjalne kołki mocujące.
(SWE)	Väggmontering fungerar som anti-lutnings skydd - det är viktigt att fästa det! En speciell plugg kan behövas för vissa väggtyper!
(FIN)	Seinäkiinnitys toimii kaatumista estävänä suojana - se on ehdottomasti kiinnitettävä! Joihinkin seinätyyppeihin voidaan tarvita erityistappi!
(NOR)	Veggmontering fungerer som anti-vippebeskyttelse - det er viktig å feste det! En spesiell dyvel kan være nødvendig for noen vegttyper!
(DAN)	Vægmontering fungerer som anti-vip beskyttelse - det er vigtigt at fastgøre det! En speciel dyvel kan være påkrævet til nogle vægtyper!
(SK)	Upevnenie na stenu slúži ako ochrana proti prevráteniu – bezpodmienečne použite! Pre niektoré druhy stien môže byť potrebná špeciálna hmoždinka!
(ES)	El montaje en la pared sirve como protección antivuelco: ¡es imprescindible fijarlo! ¡Es posible que se requiera una espiga especial para algunos tipos de paredes!

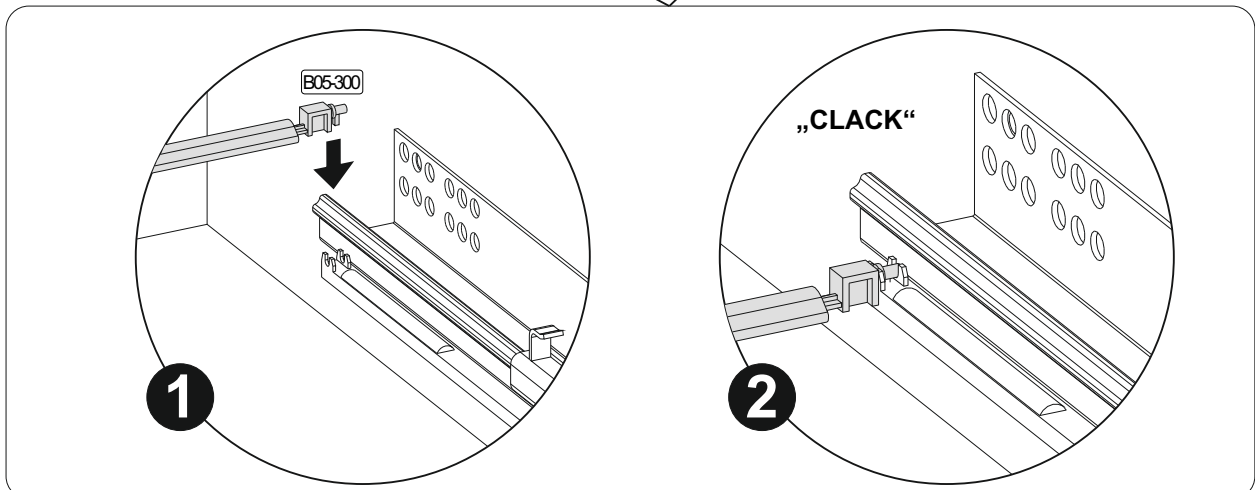
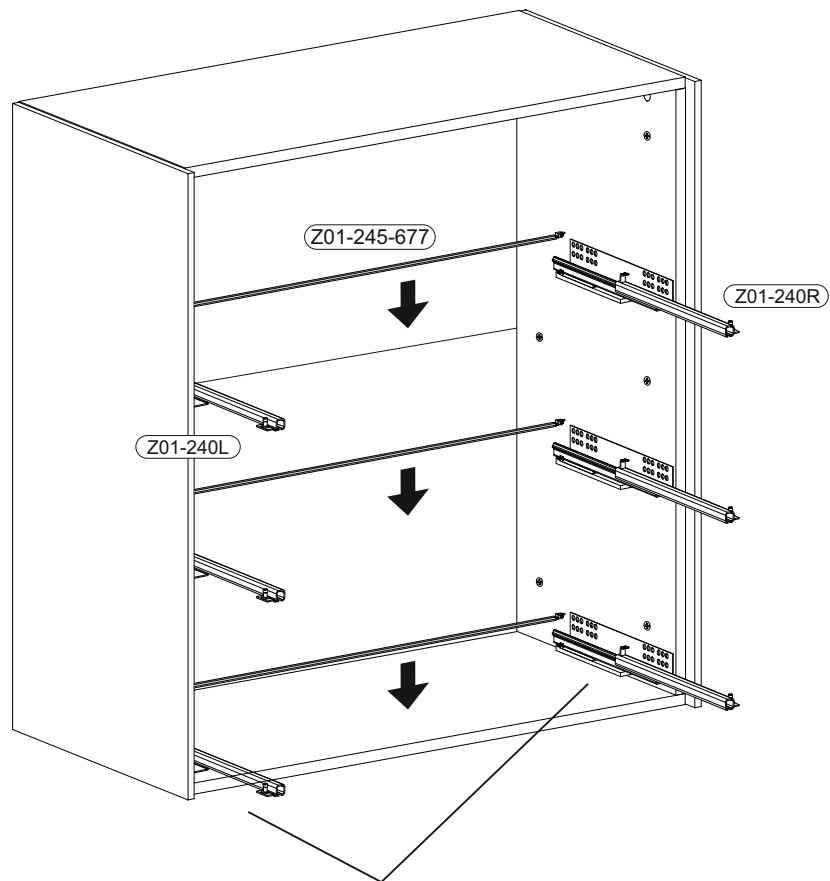
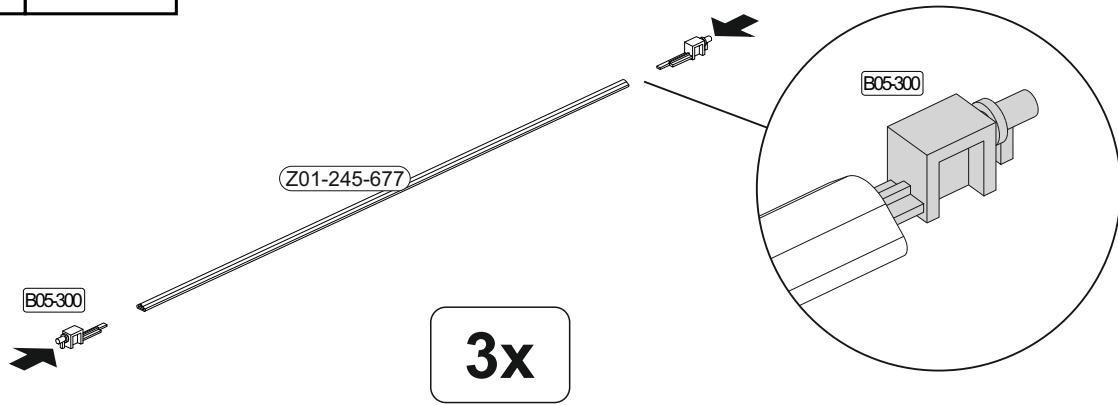
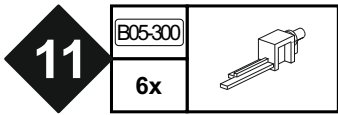

13

	B02-10		B02-20		B02-103		B01-122		B01-30	
	8x	ø15x12mm	8x		16x	8x30	4x	4,0x13	12x	3x16

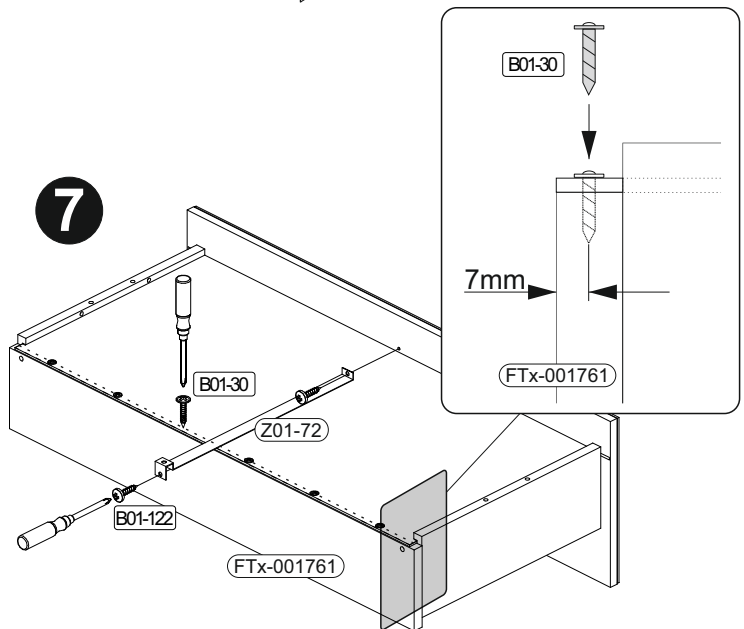
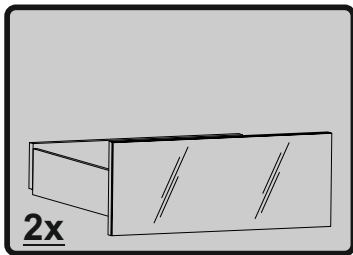
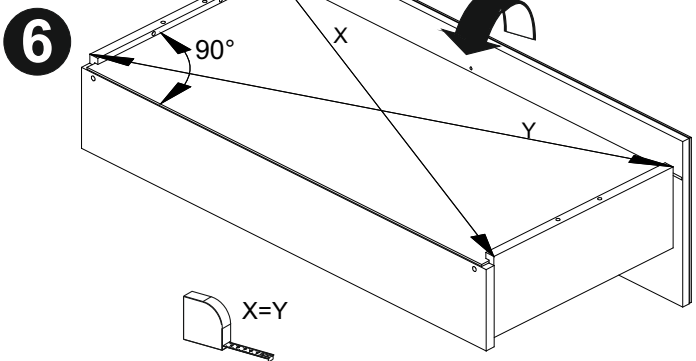
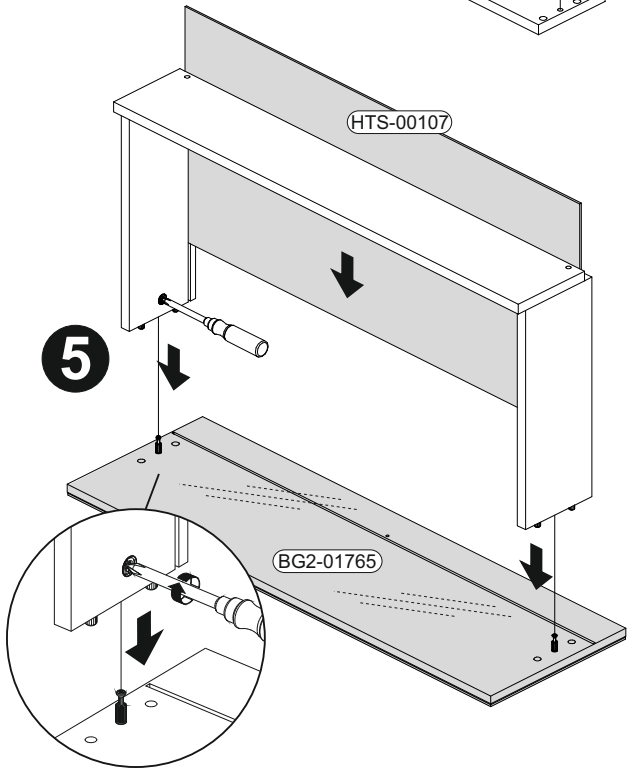
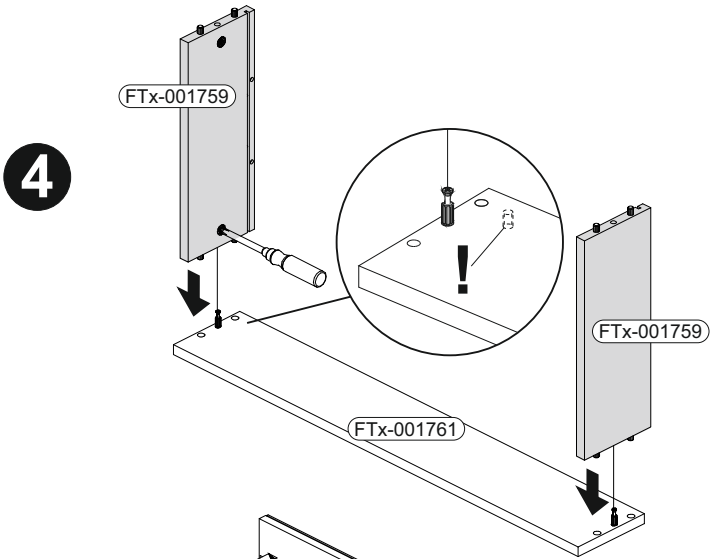
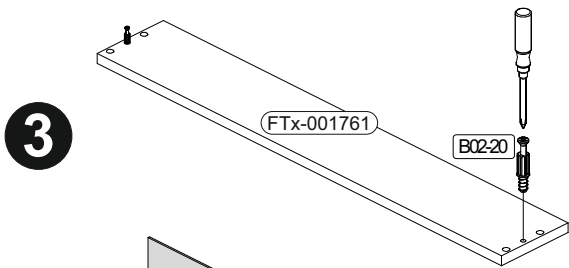
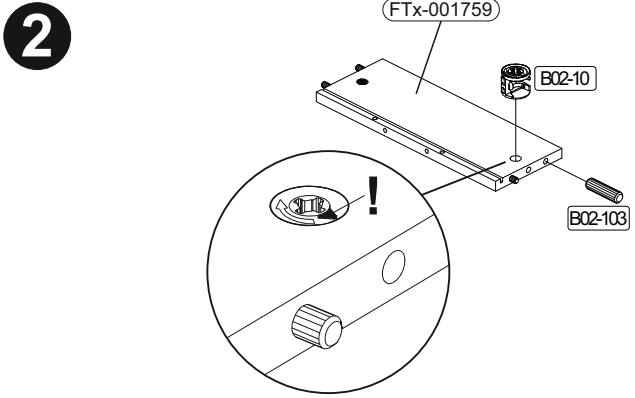
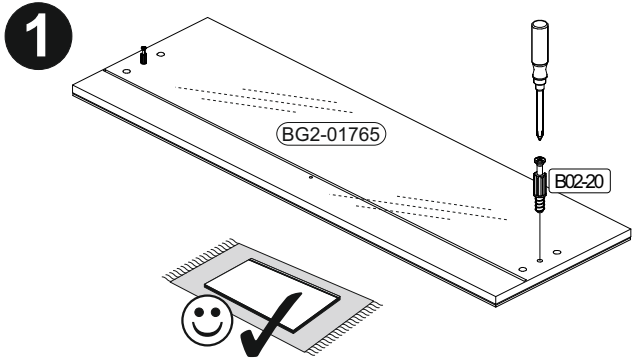

14

		B02-10		B02-20		B02-103		B01-30	
		8x	ø15x12mm	8x		8x	8x30	6x	3x16

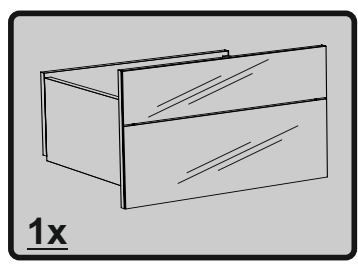
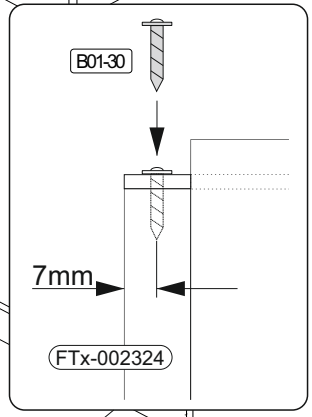
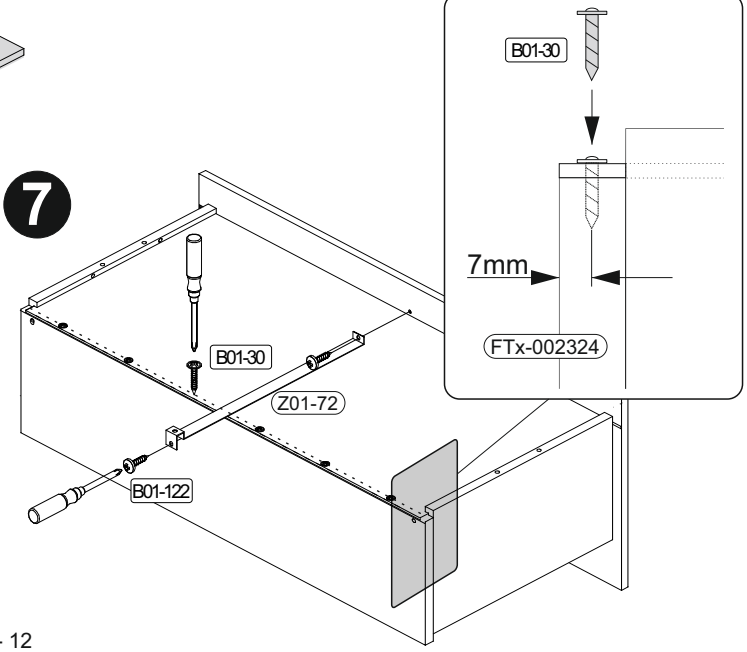
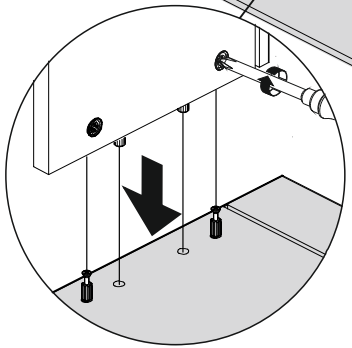
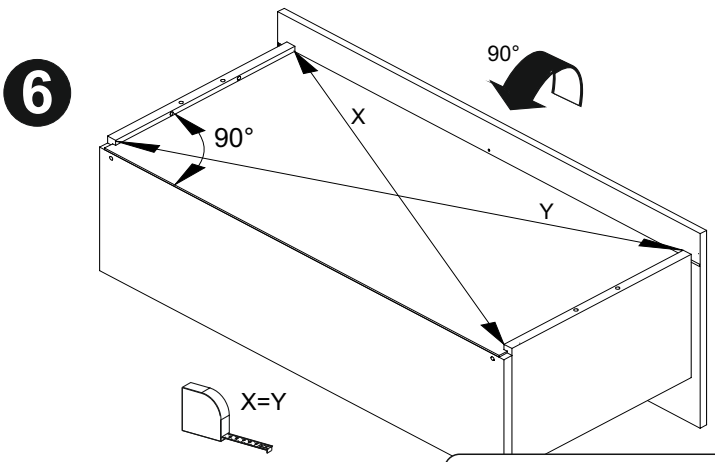
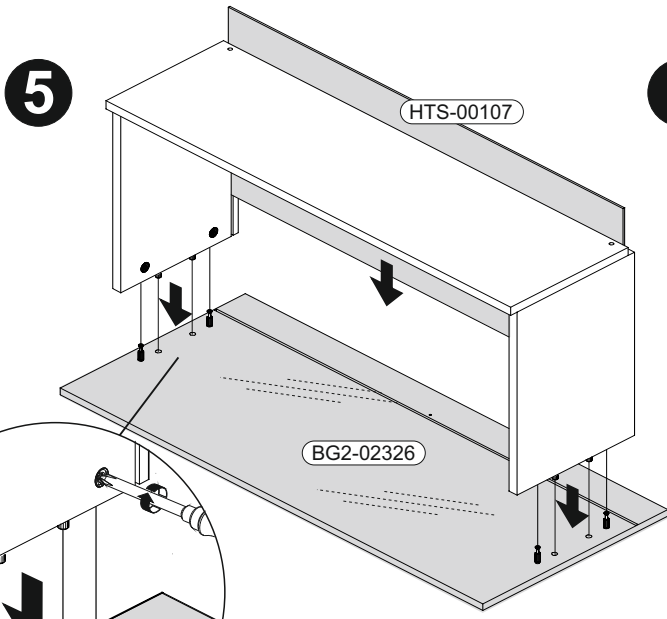
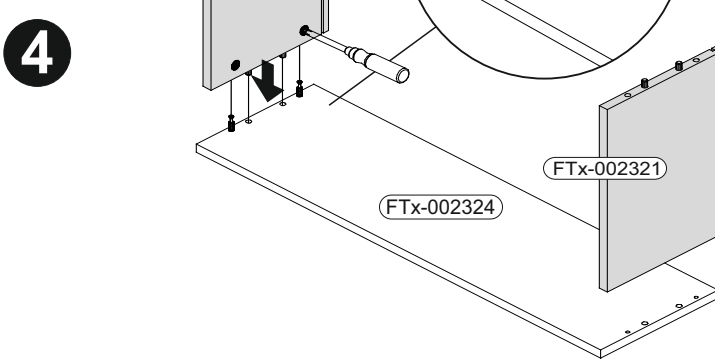
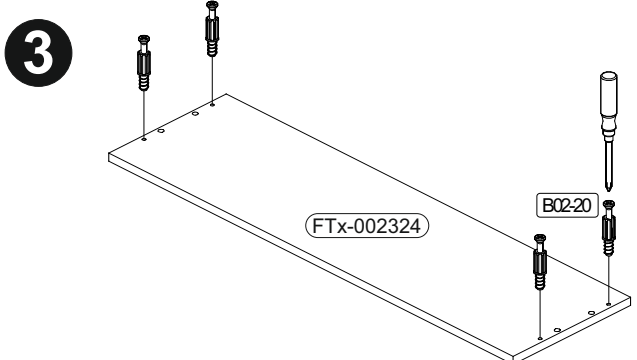
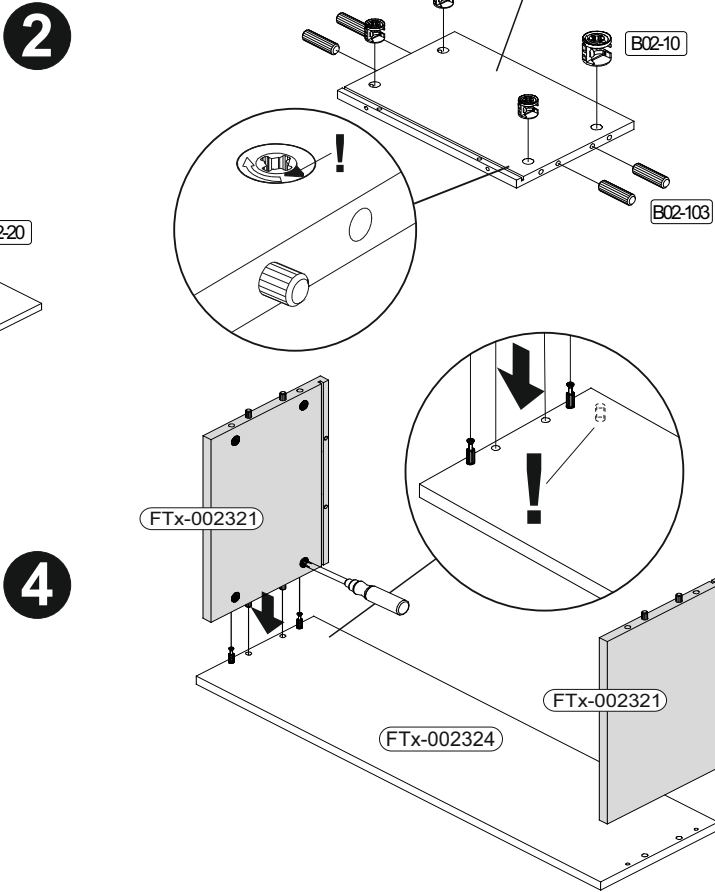
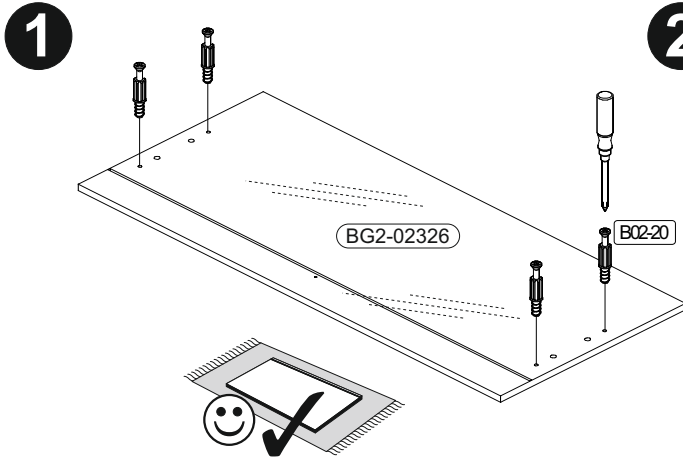

15

B05-302		B05-301		B05-20		B03-134	
3x		3x		16x		9x	

