

REPC-Nr.:

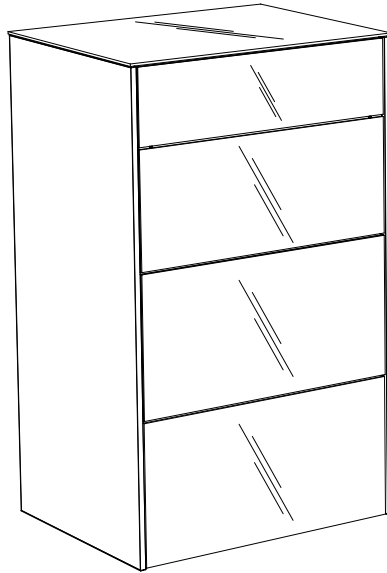

Artikel.-Nr.:

8002-KO-03-52

Montageanleitung.-Nr.:

MA1-00691

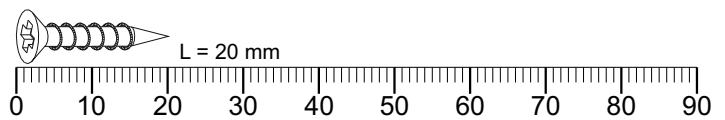
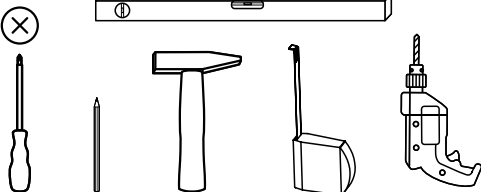
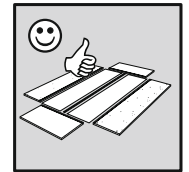
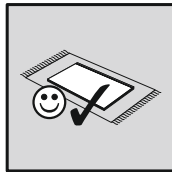
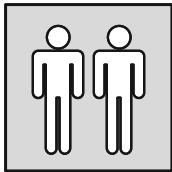
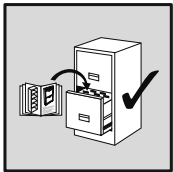

SCAN ME

Das Ersatzteil-Anforderungsformular finden Sie auf
The replacement parts requisition form you find on
<https://www.mausbacher.de/ersatzteile/>

Colli 1/2



BT1-00796

B03-134		B05-185	
9x		4x	
B05-300		B05-301	
6x		3x	
B05-302			
3x			

BT1-00795

B01-10		B01-190	
4x	6,3x50	12x	M4x20
B01-200		B01-30	
12x	6,3x13	15x	3x16
B01-347		B01-90	
12x	5x8	4x	3,5x20
B02-10		B02-20	
20x	ø15x12mm	20x	
B08-80		B05-20	
1x		16x	
B02-103			
24x	8x30		

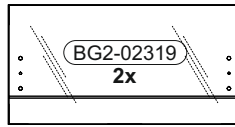

492 x 253

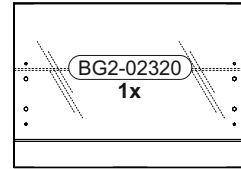

492 x 348

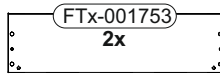

457 x 124

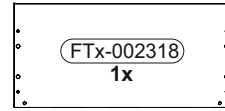

457 x 220

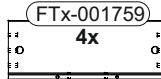

335 x 124

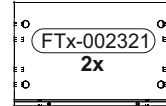

335 x 220

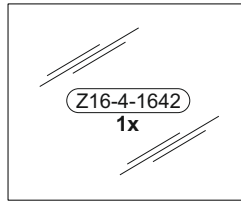

522 x 419

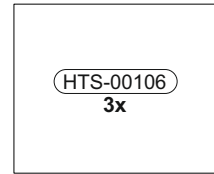

438 x 358

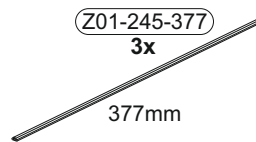

377mm

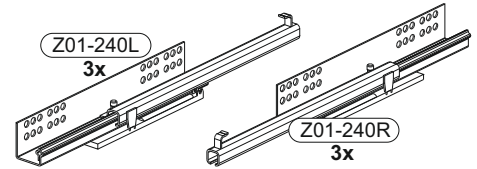

3x

3x

BT1-00005

B02-173		B01-123	
4x		8x	4,0x15

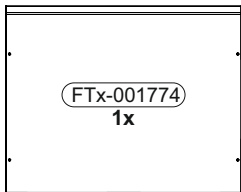

498 x 394

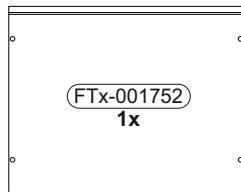

498 x 394

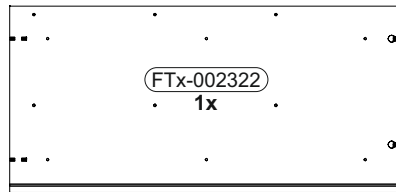

832 x 394

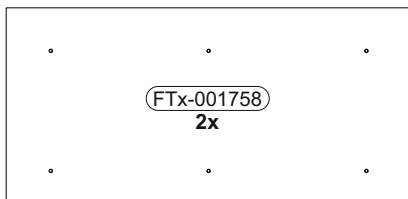

862 x 417

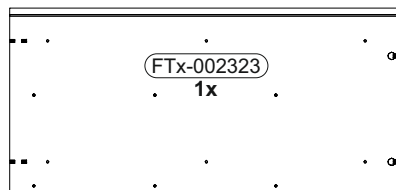

832 x 394

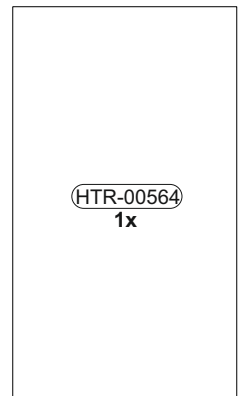

844 x 480

Colli 2/2

1

	B02-10		B01-200	
	2x	ø15x12mm	6x	6,3x13

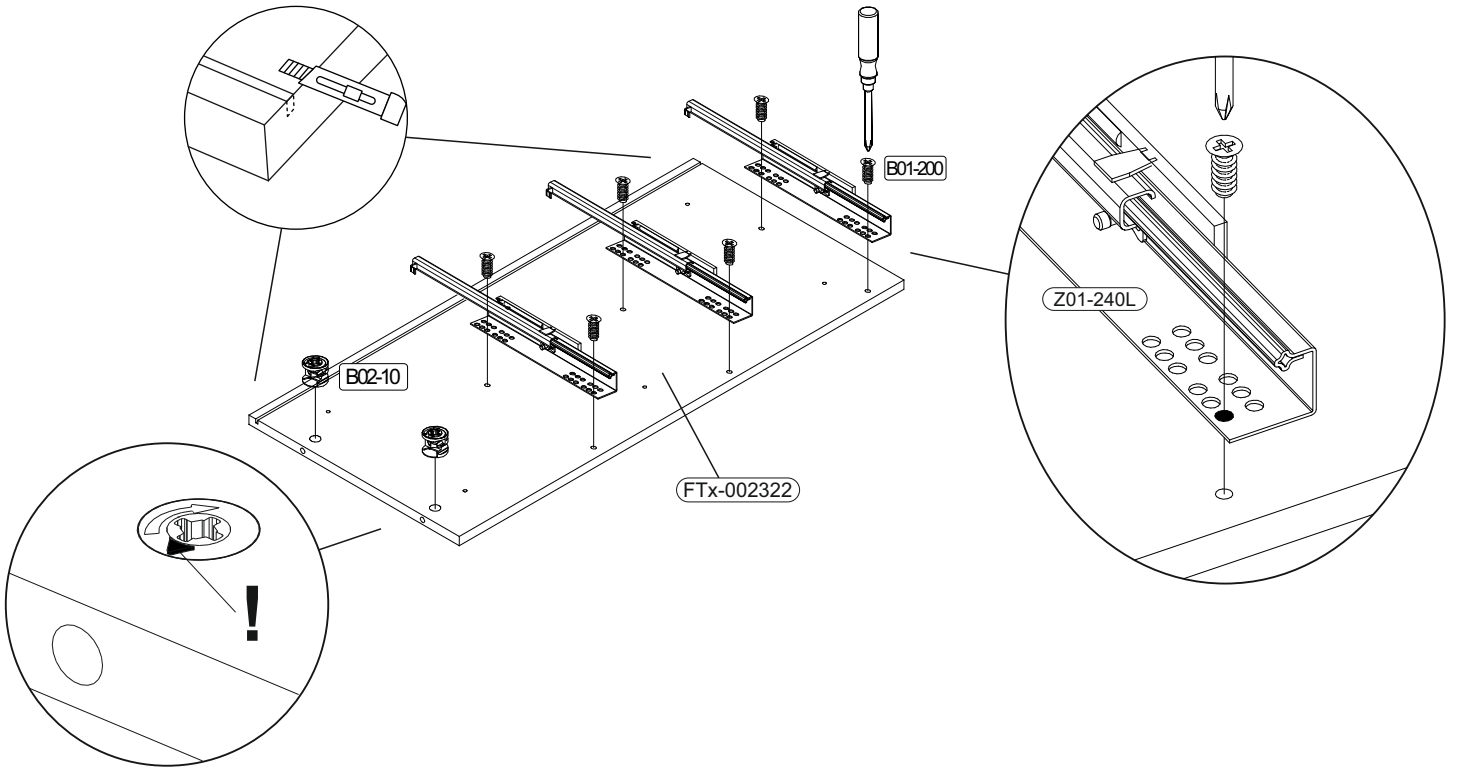

2

	B02-10		B01-200	
	2x	ø15x12mm	6x	6,3x13

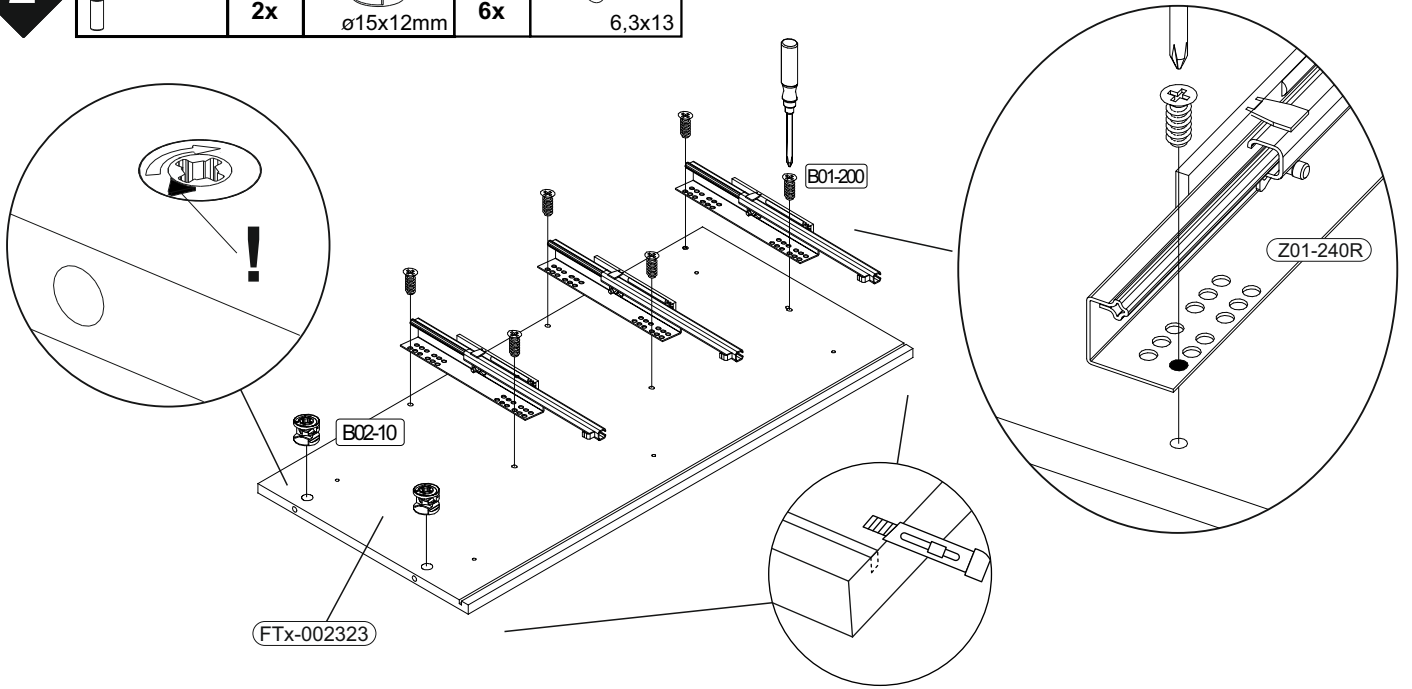

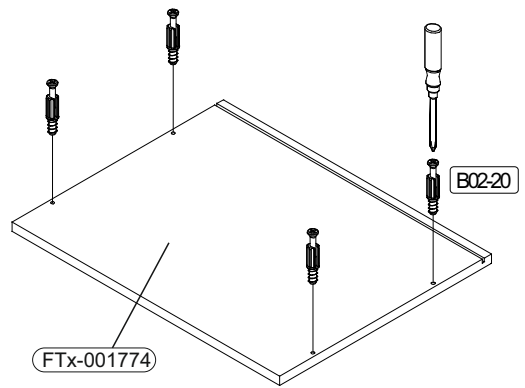

3

	B02-20	
	4x	



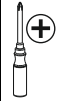

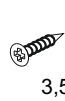
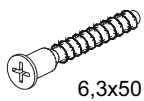

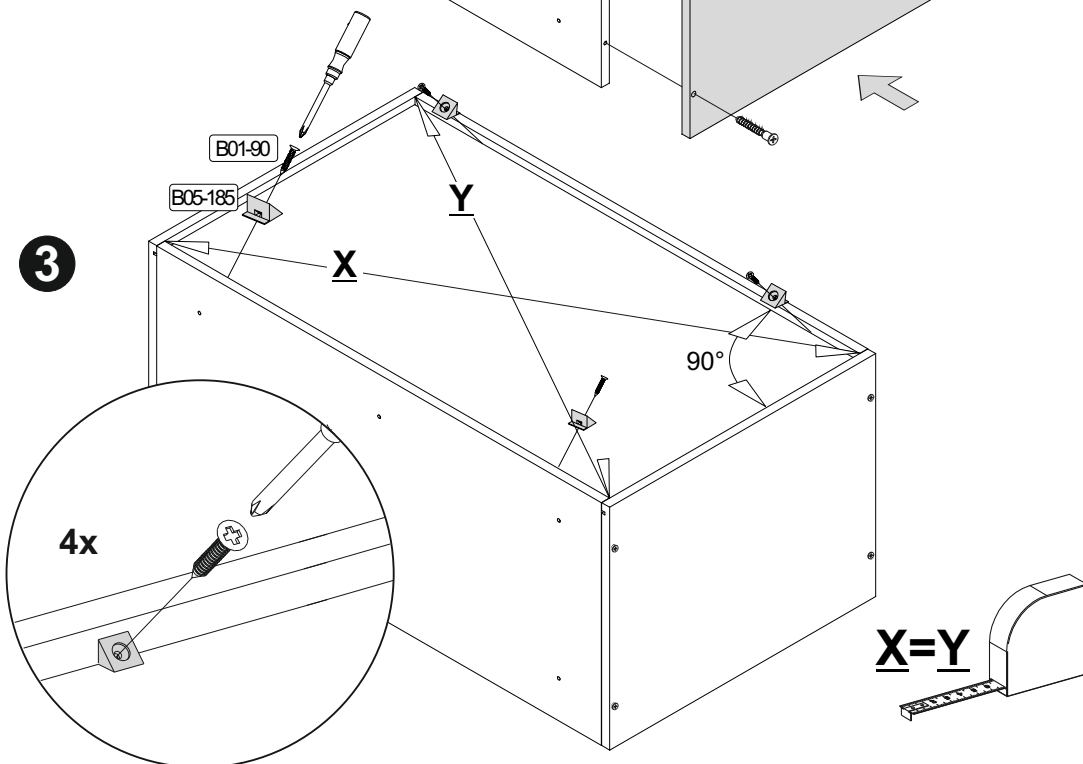
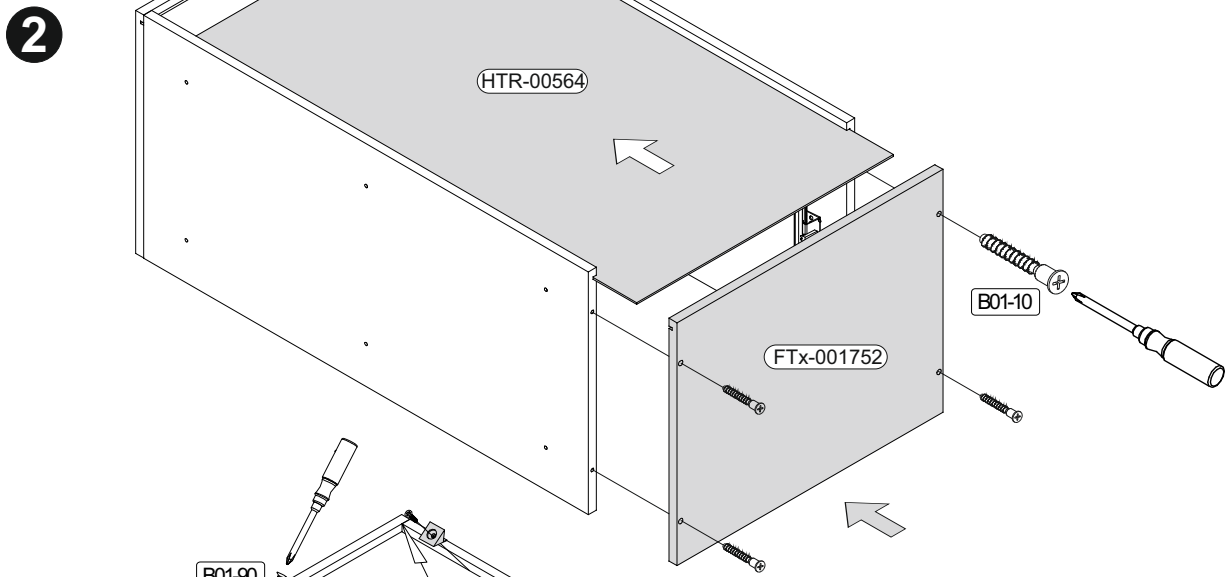
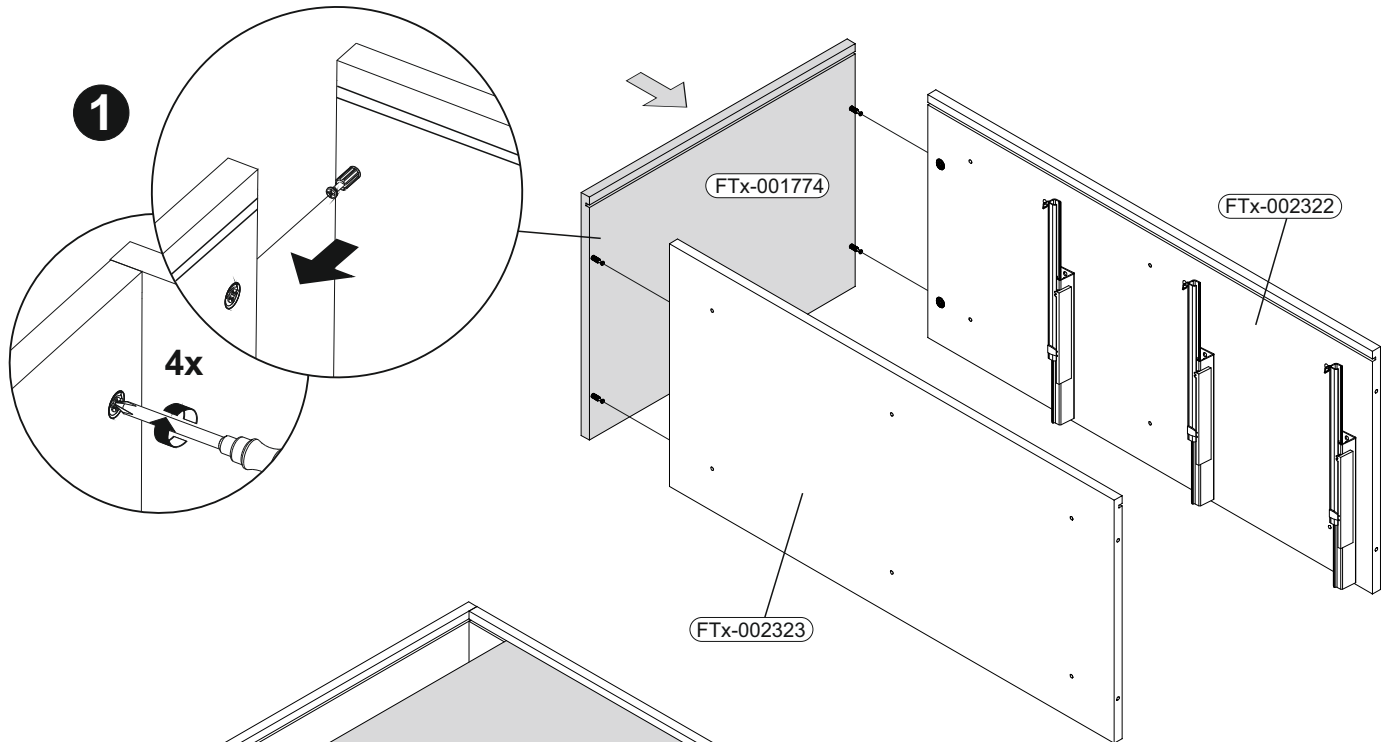
4

		B05-185		B01-90		B01-10	
		4x		4x	3,5x20	4x	6,3x50

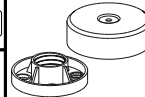

5

		B02-173		B01-123	
		4x		8x	4,0x15

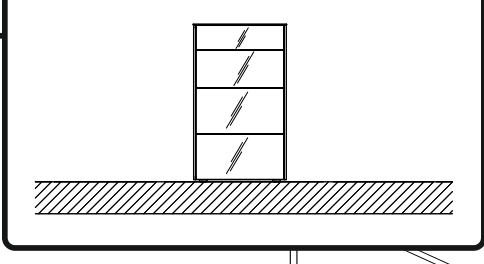
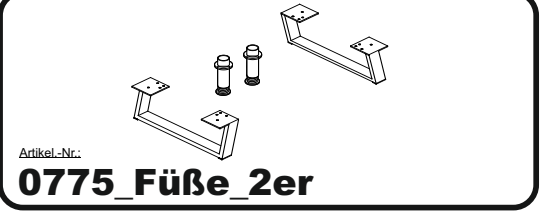
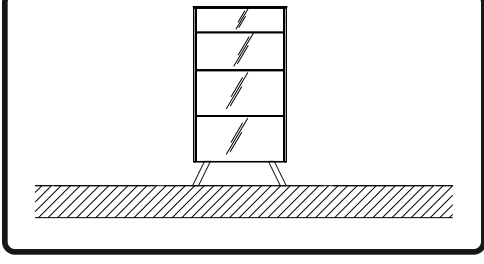
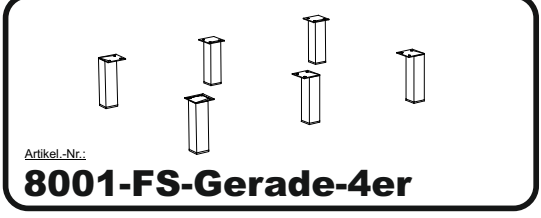
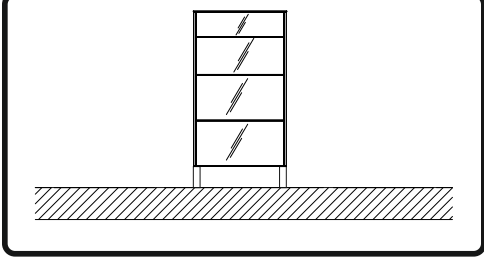
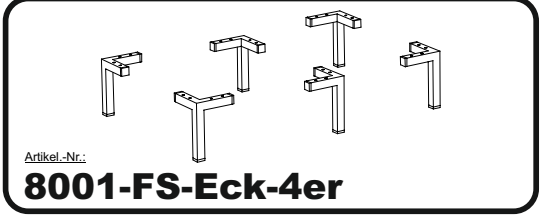
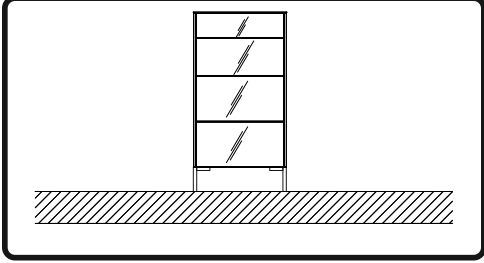
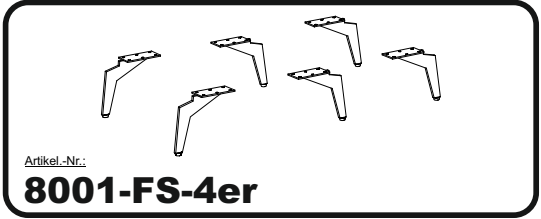
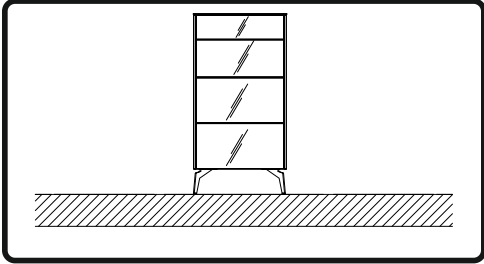
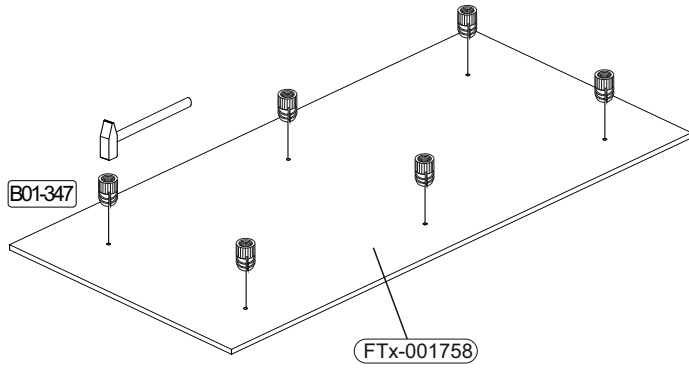
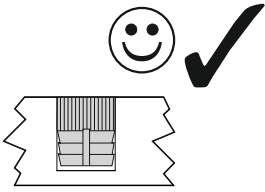
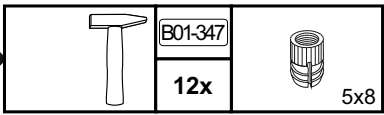

Diagram showing the cabinet's bottom panel with dimensions: 55mm between screws, 45mm from edges, and B02-173 labels. A circular inset shows a close-up of a screw being inserted into a hole, labeled with B02-173 and B01-123. A second circular inset shows a close-up of a bracket being attached to the bottom panel, labeled with B02-173 and 4x.

6



2x

7

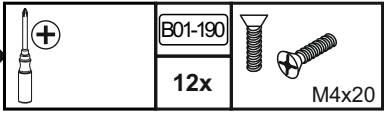

1

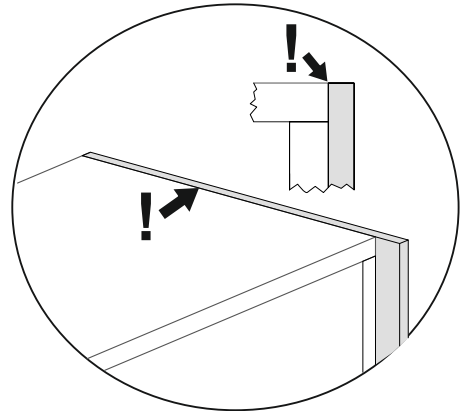
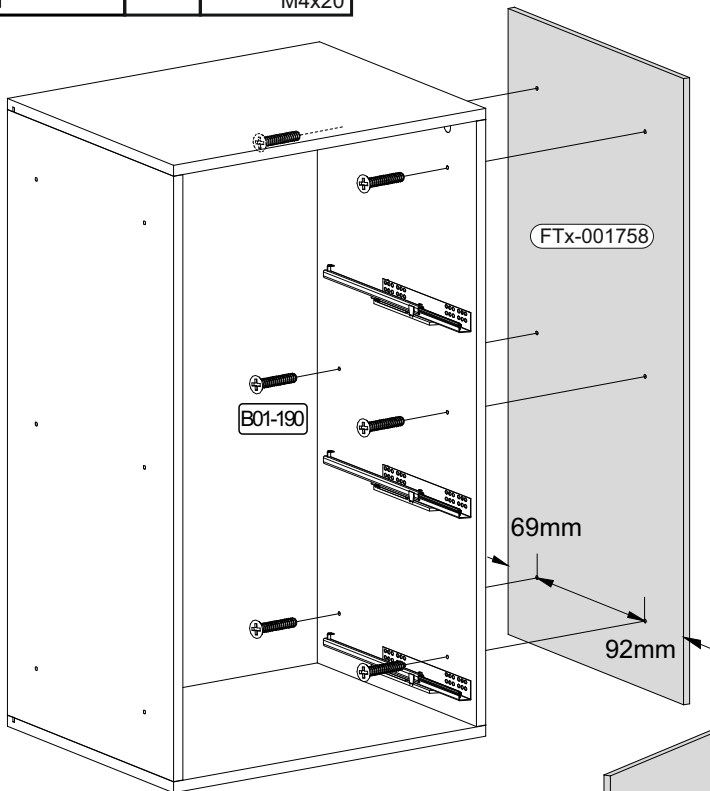

2

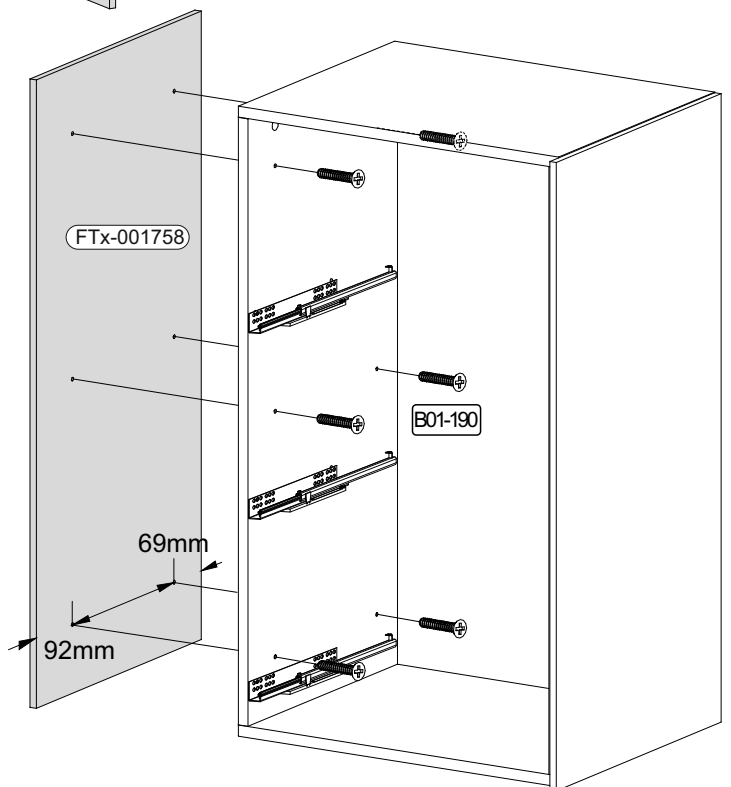



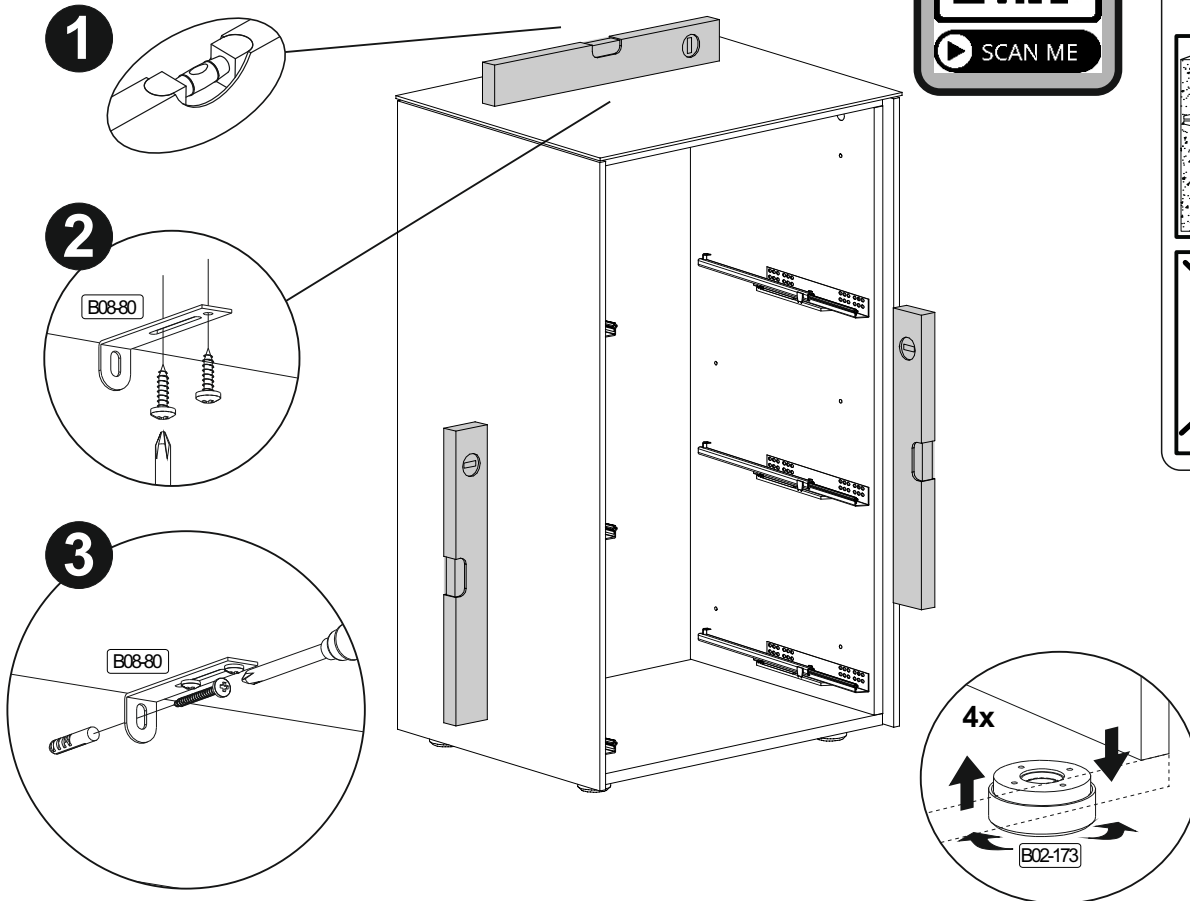
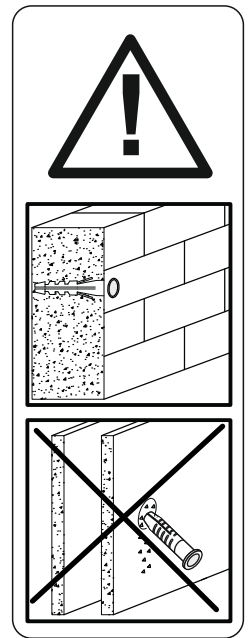
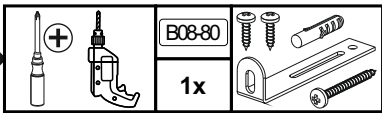



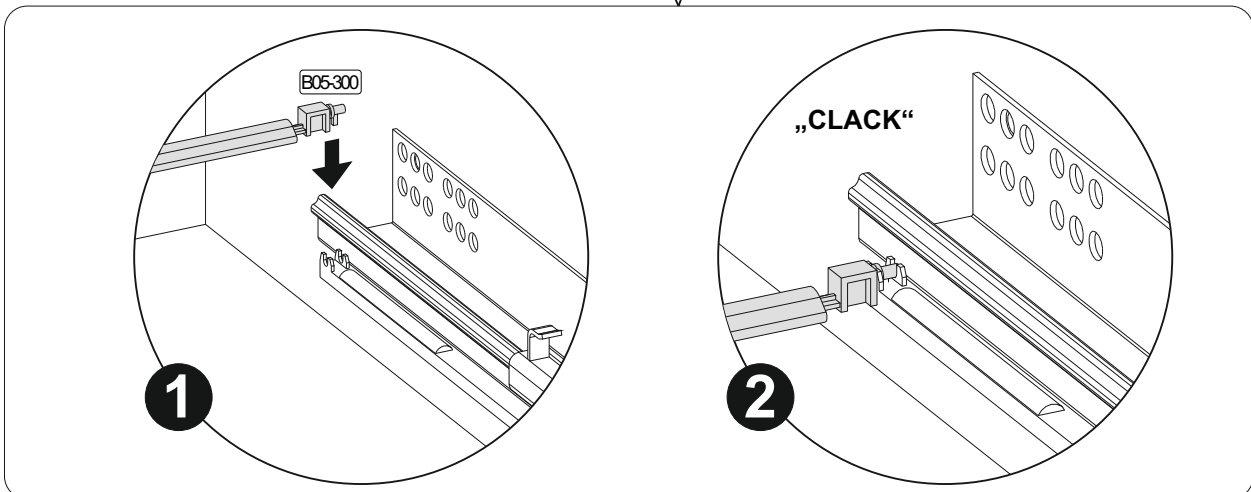
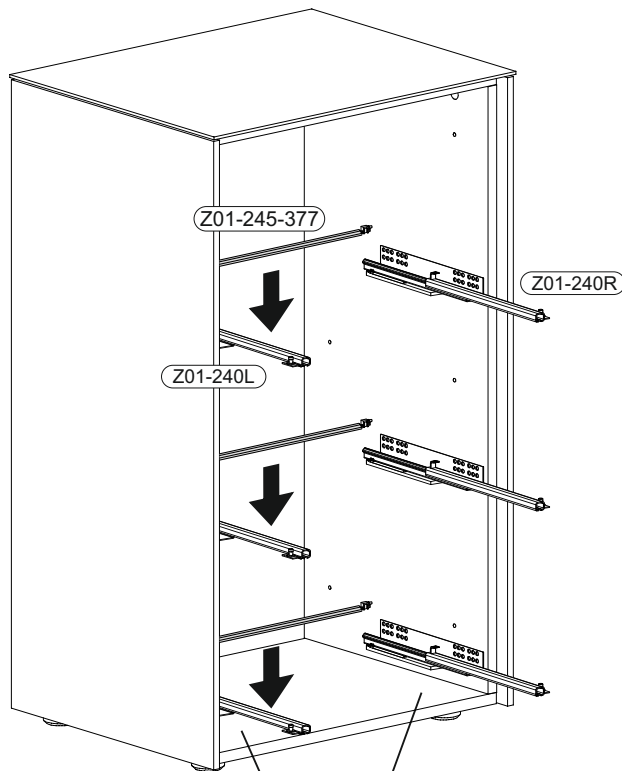
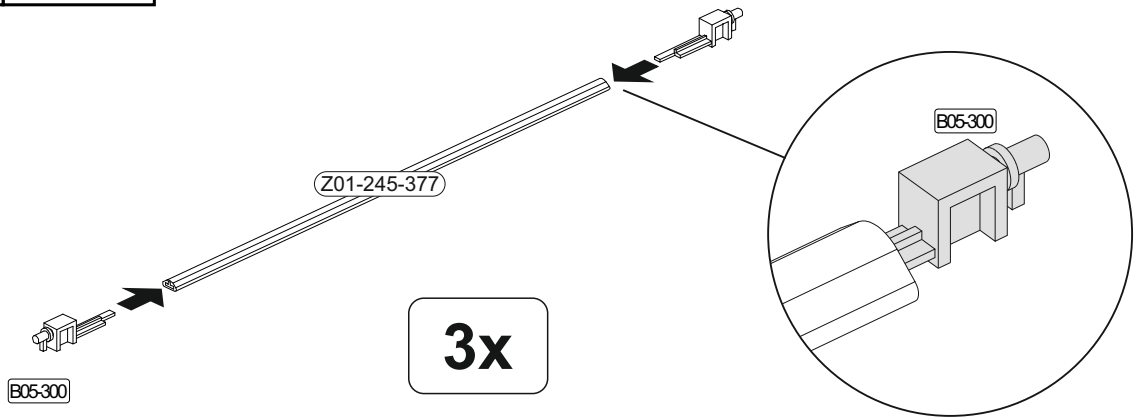
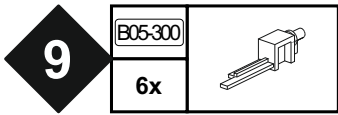

8



Achtung • Attention • Attenzione • Opgelet • Uwaga • Pozor • Figyelem • Atenție • Dikkat • Внимание • Fara • Vaara • Fare • Peligro	
(D)	Wandbefestigung dient als Kippschutz - unbedingt anbringen! Bei einigen Wandtypen kann ein Spezialdübel erforderlich sein!
(GB)	The wall fastening serves to prevent tipping - be absolutely sure to mount it! For certain wall types, a special wall plug may be necessary!
(FR)	La fixation murale sert de protection contre le basculement – à installer impérativement ! Pour certains types de murs il faut des chevilles spéciales !
(TR)	Duvardaki sabitleme, devrilmeye karşı bir emniyet tedbiridir ve mutlaka monte edilmelidir! Bazı duvar tiplerinde bunun için özel bir dübel gerekli olabilir!
(IT)	Il fissaggio alla parete serve da protezione anti-ribaltamento – attaccarla assolutamente! Per alcune strutture di parete può essere necessario un tassello speciale!
(NL)	Bevestiging aan de muur dient als kantelbescherming – zeker en vast bevestigen! Bij enkele muurtypes is een speciale plug misschien vereist!
(RU)	Обязательно установите крепление на стене во избежание опрокидывания! Для некоторых типов стен может потребоваться специальный дюбель!
(CZ)	Montáž na stěnu slouží jako ochrana proti převrnutí – bezpodmínečně umístěte! U některých typů stěn může být zapotřebí speciální hmoždinka!
(HU)	A termék a falhoz kel rögzíténi, különben az felborulhat! Egyes faltípusoknál speciális tiplit kell használni!
(RO)	Sistemul de fixare la perete servește ca protecție la răsturnare - de montat obligatoriu! Pentru unele tipuri de pereți este posibil să fie necesar un diblu special!
(PL)	Mocowanie do ściany jest jednocześnie zabezpieczeniem przed przewróceniem – koniecznie zamontować! Do niektórych rodzajów ścian koniecznie zastosować specjalne kołki mocujące.
(SWE)	Väggmontering fungerar som anti-lutningssskydd - det är viktigt att fästa det! En speciell plugg kan behövas för vissa väggtyper!
(FIN)	Seinäkiinnitys toimii kaatumista estävänä suojana - se on ehdottomasti kiinnitettävä! Joihinkin seinätyypeihin voidaan tarvita erityistappi!
(NOR)	Veggmontering fungerer som anti-vippebeskyttelse - det er viktig å feste det! En spesiell dyvel kan være nødvendig for noen vegttyper!
(DAN)	Vægmontering fungerer som anti-vip beskyttelse - det er vigtigt at fastgøre det! En speciel dyvel kan være påkrævet til nogle vægtyper!
(SK)	Upevnenie na stěnu slúži ako ochrana proti prevráteniu – bezpodmienečne použite! Pre niektoré druhy stien môže byť potrebná špeciálna hmoždinka!
(ES)	El montaje en la pared sirve como protección antivuelco: ¡es imprescindible fijarlo! ¡Es posible que se requiera una espiga especial para algunos tipos de paredes!



11

		 B02-10 8x	 B02-20 ø15x12mm	 B02-20 8x	 B02-103 16x	 B01-30 8x30	 B01-30 10x	 3x16
--	--	--	--	--	--	--	---	--

1

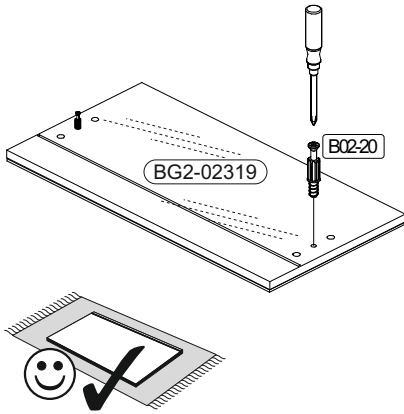

2

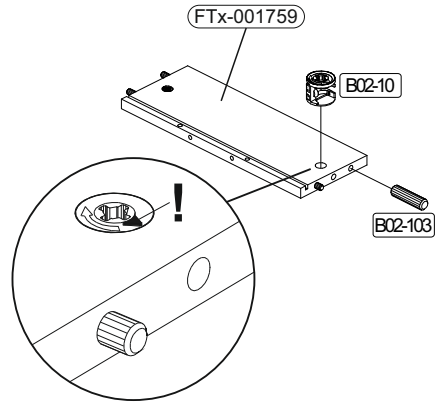

3

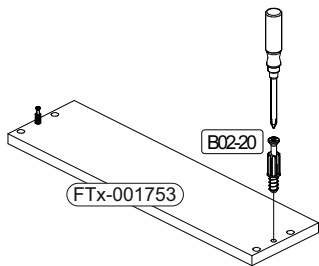

4

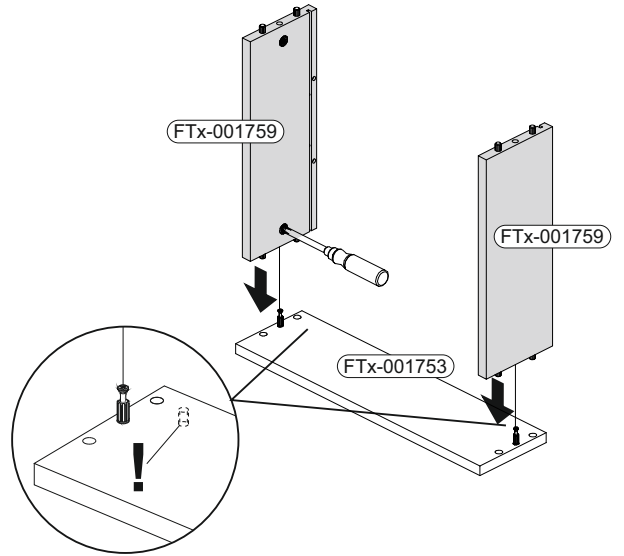

5

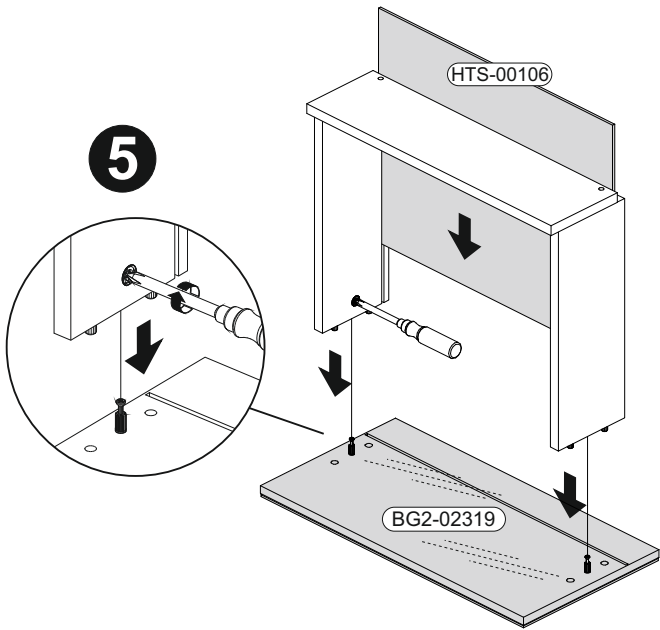

6

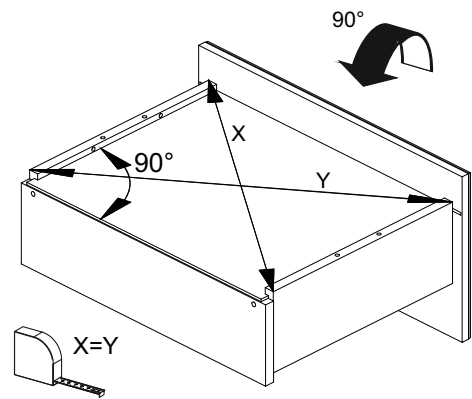

7

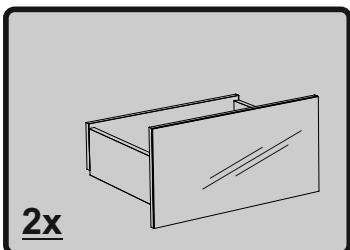
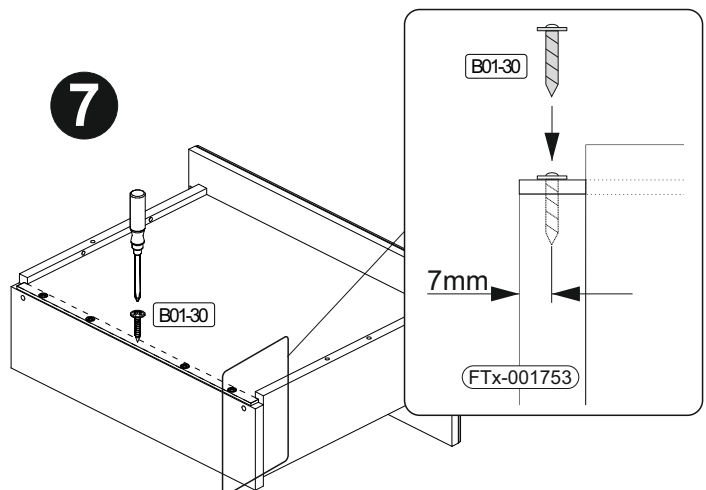

12

		B02-10 8x	 ø15x12mm	B02-20 8x		B02-103 8x	 8x30	B01-30 5x	 3x16
--	--	---------------------	--------------	---------------------	--	----------------------	----------	---------------------	----------

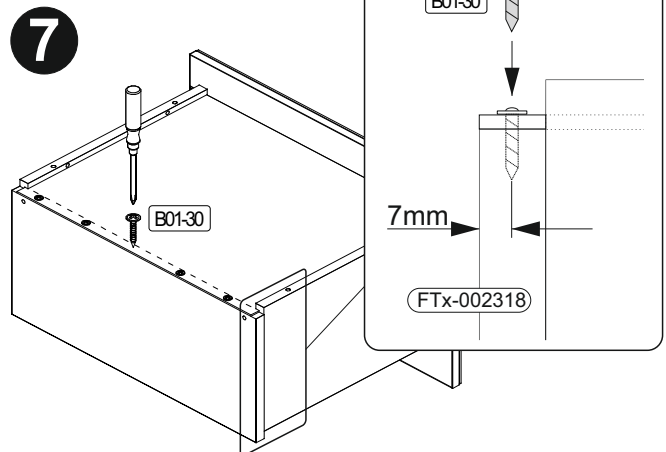
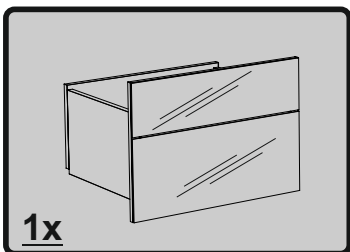
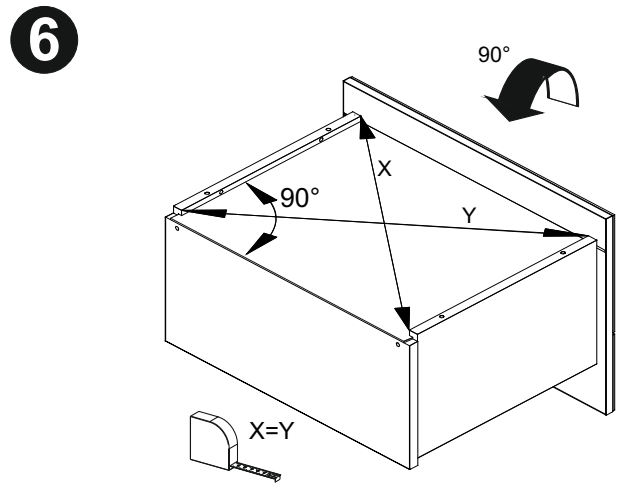
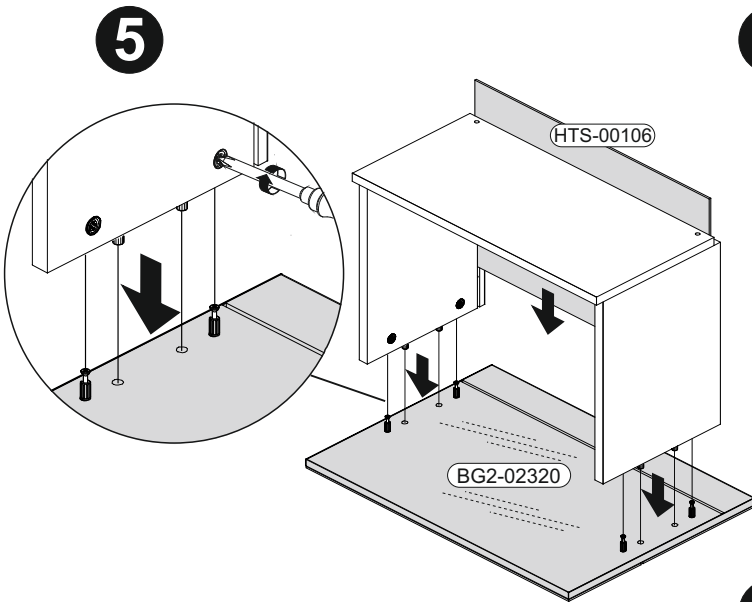
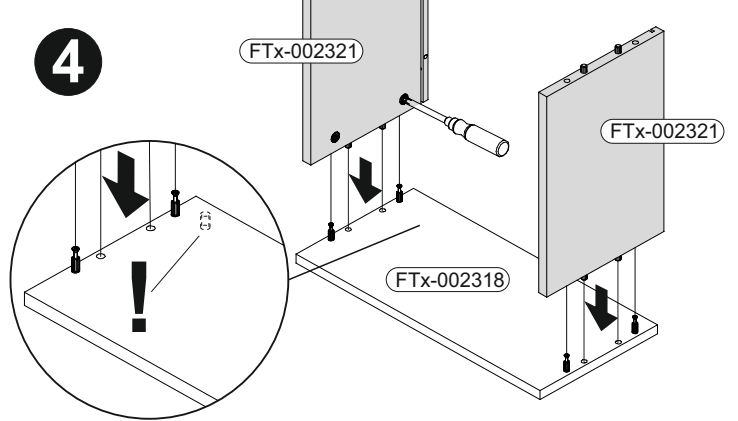
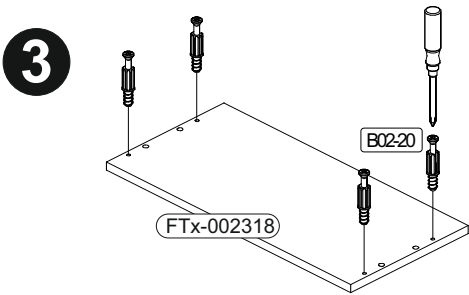
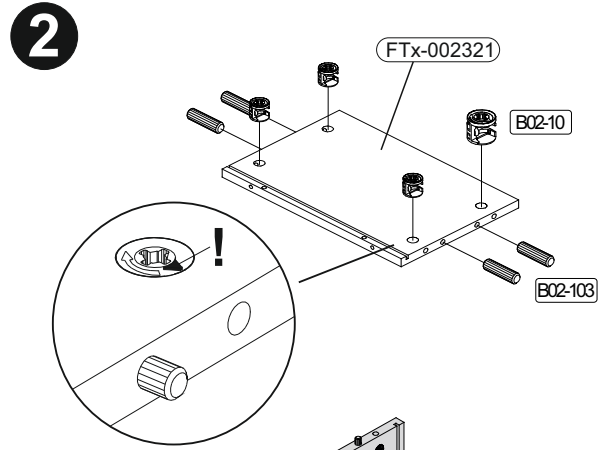
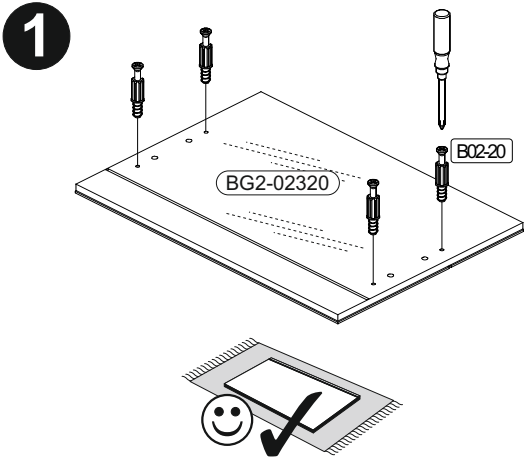

13

B05-302		B05-301		B05-20		B03-134	
3x		3x		16x		9x	

